

Mr. Mark Cedergreen
Chairman
Pacific Fishery Management Council
7700 NE Ambassador Place, Suite 101
Portland, Oregon 97220-1384
May 18, 2011

RE: Electronic Monitoring Pilot Study Report for West Coast Groundfish Trawl ITQ Program

Dear Mr. Chairman,

The purpose of this letter is to submit to the attention of the Pacific Fishery Management Council a report summarizing results and recommendations from the Electronic Monitoring (EM) pilot study that was conducted as part of the recent Exempted Fishing Permit work off of Morro Bay, California. The stated goal of this research is to help in the development of an objective, reliable and cost-effective monitoring program based on individual accountability using video based Electronic Monitoring tools, as well as to explore how Electronic Monitoring could be implemented in the West Coast Groundfish Fishery.

Over the last several years Council members and staff have demonstrated great leadership and innovation in designing an ITQ program and addressing the top concerns that come with this management transition. The Council's work on Community Fishing Associations and Risk Pools to help resolve community stability and overfished species management issues are examples of the strong work being done by the Council on this program. These efforts are having a national impact as other fisheries look to the West Coast Groundfish Fishery for examples and models of how to best design and implement Catch Share management programs.

Just as crucial to the success of this ITQ program will be designing cost effective methods for the fishery to achieve its monitoring goals. In this first year of the ITQ program, the fishery relies on federal assistance to support monitoring costs. As we all know, once that assistance is no longer available, the additional cost placed on the industry will have significant consequences, particularly on small vessels and vessels engaging in gear switching. It is very likely that the additional costs could be the tipping point for many smaller scale fishery operations and communities that have traditionally participated in the fishery. It is imperative that the fishery makes progress on the design of more cost effective monitoring now, so to prepare for this inevitable cost burden. We and many other fishery stakeholders believe that Electronic Monitoring will be an important component of the solution.

The attached report describes the Electronic Monitoring pilot work that included video and sensor data that was collected from six vessels and monitored by this equipment over a 5 ½ month period including a total of 332 hauls for over 125 sea days. This robust data set compared piece counts for the number of fish recorded from 3 different sources collected independently of each other: observer, fishermen logbooks, and EM. Overall agreement was strong between the 3 sources, with Electronic Monitoring being comparable to both observer and fishermen logbook

data. EM data had 1% less pieces than observer data, with high agreement on piece counts for sablefish (1% difference) and grouped rockfish (4% difference). There was a 0% difference in piece counts between EM and logbook data, and 1% more and 4% less for sablefish and rockfishes respectively. Out of 329 fishing events captured on video, only one was unusable due to poor lighting during a night haul when the deck lights failed.

At this moment in the development of the ITQ structure, we encourage the Council to work with NMFS to take the action necessary to begin the implementation of the new Electronic Monitoring program for this fishery. We would also submit the following recommendations, which we feel would facilitate the start of an Electronic Monitoring program and improve the chance for long terms success.

- While we believe Electronic Monitoring can be useful in the monitoring of all types of groundfish vessels, it is clear that lower volume operations, such as fixed gear boats, make for an easier operation to monitor. In order to get a start with Electronic Monitoring and develop more experience with these systems, we would encourage that the Council pursue a “low hanging fruit” strategy and allow fixed gear boats to be the first to utilize a new Electronic Monitoring system.
- We would encourage the use of depth and other spatial restrictions for the early implementation of Electronic Monitoring to help separate the development of this program from the complexity of the most severe overfished species concerns.
- We urge implementation of an Electronic Monitoring pilot program in the West Coast Trawl ITQ program beginning no later than Jan. 1, 2012 to minimize the dislocation that will occur in the trawl ITQ program due to the cost of existing 100% human observer coverage. There is real urgency in this recommendation as we know that many long term business planning decisions will be made by fishermen in the first two years of the Trawl ITQ program, and immediate implementation will reduce cost inputs in business planning, reducing the negative community impacts from consolidation of the smaller boat operations.
- We request that the council pursue development of a trailing amendment, including criteria that an authorized EM system would need to meet, under the next round of trailing amendments to the trawl rationalization program.

Thank you for your continued efforts to design and implement an ITQ program that will meet the objectives of the many fishery stakeholders that participate in this fishery. This Council’s leadership has been the key ingredient to all progress in this program to date, and we strongly encourage you to take up Electronic Monitoring as a top priority for your future efforts.

Sincerely,
Michael Bell
Senior Project Director
The Nature Conservancy of California

**USE OF AN ELECTRONIC MONITORING SYSTEM TO ESTIMATE
CATCH ON GROUND FISH FIXED GEAR VESSELS IN MORRO
BAY CALIFORNIA- PHASE II**

by

Jason Bryan
María José Pría Ramos
Howard McElderry

Archipelago Marine Research Ltd.
525 Head St.
Victoria, British Columbia, Canada
V9A 5S1
www.archipelago.ca

May 19th, 2011



EXECUTIVE SUMMARY

Bryan, J, Pria, M.J. and H. McElderry, 2011. Use of an Electronic Monitoring System to Estimate Catch on Groundfish Fixed Gear Vessels in Morro Bay California- Phase II. Unpublished report prepared for The Nature Conservancy by Archipelago Marine Research Ltd., Victoria British Columbia, Canada. 51 p.

In 2010, TNC contracted with Archipelago to expand upon a 2008 pilot project in Morro Bay and test an EM system's capability to accurately record fishing events to meet the catch monitoring needs for the IFQ in an economically marginal fishery. This 2010 study represents a unique opportunity to gain further insight on how to develop an objective, reliable and cost-effective monitoring program for a fixed gear, small vessel fleet based on individual accountability using video based electronic monitoring (EM) tools as well as to explore how an audit-based monitoring system could be implemented in order to decrease the cost burden for individual fishermen.

EM systems consisted of up to four closed circuit television cameras, a GPS receiver, a hydraulic pressure transducer, a winch rotation sensor, and a system control box. EM sensor data, comprised of date, time, location, pressure and rotation sensor readings and EM system metadata, were recorded continuously while the system was powered, which was for the entire duration of the fishing trip (i.e. from the time the vessel leaves port to engage in fishing to the time that the vessel returns to port). Readings from the GPS, pressure and rotation sensors were used to detect fishing activity and triggered video recording. All of the sensor data and video footage was subsequently reviewed to create a complete characterization of fishing effort and catch and discards for participating vessels, which then could be compared to data from observers and fishing logs.

Six vessels were monitored over a five and a half month period and for a total of 332 hauls detected over 125 days at sea. EM system data collection was 91% overall for all participating vessels and trips and the majority of the data lost was of low risk since it occurred during transit to and from the fishing grounds. Every vessel carried an observer and skippers filled out a haul-by-haul fishing logbook for every trip. The EM data collected was matched up and used for catch assessment comparisons with 97% of all hauls recorded by observer and fishing log.

EM and observer fishing event and catch data were available for over 105,000 total fish catch items and a total of 276 fishing events. EM data had 1% less pieces of catch than observer overall, with high agreement on piece counts of sablefish (1% difference) and grouped rockfish (4% difference), the two most important species groups of this study (for market and conservation reasons, respectively). There were 328 events compared between EM and fishing log data. The total piece comparison between EM and fishing log data was very good, since fishing log data contained 0% different total catch items and 1% more and 4% less items for sablefish and rockfishes respectively. Out of 329 fishing events captured on video, only one was unusable due to poor lighting during a night haul when the deck lights failed and the catch was processed using headlamps. While sun glare and backlighting by deck lights during night hauls

can adversely affect video quality, determining catch count and composition was typically unimpacted.

Development of an EM based audit methodology was one of the deliverables of this project. Since EM data collection and data processing and analysis occur at different stages, the technology allows for capture of all fishing activity at-sea without the need to engage in data interpretation for all of it. However, since EM captures all of the fishing activity, it can be used to fully reconstruct a fishing trip in cases where the fishing log is not deemed accurate. Benefits of an audit-based monitoring program include (Stanley *et al.*, in press): cost and logistically effective 100% data capture, fishermen with a vested involvement in reporting, transparent and trusted catch estimates, financial motivation to comply, and an independent estimate of catch.

The proposed audit methodology follows the example presently in use in BC, Canada. Fishing logbook entries for retained and discarded catch for an agreed percentage of hauls are compared to the EM monitoring results. Dockside monitoring programs are used to check the amount and composition of retained catch when a vessel returns to port. The fishing log is compared to the EM and dockside monitoring data and scored on its accuracy, and has to meet several pass/fail standards as well. As long as the fishing log data is accurate, an update to that fishing licence's quota is issued and the vessel is free to resume fishing. If there are discrepancies in the fishing log, a series of escalating actions occur to resolve the discrepancies and encourage future compliance and then an update to that fishing licence's quota is issued. Estimates of the cost for such a program would be difficult to determine for the West Coast fishery presently, primarily due to uncertainties regarding the level of video review, frequency of data collection and turnaround time for updated vessel quota reports needed to support adequate monitoring needs. These in turn would have to be determined by fishery managers who would set guidelines on the appropriate level of video review and data collection needed to meet the monitoring requirements for this fishery. The only system to currently compare it to is an audit-based EM program that delivers a finished data product integrating hail, fishing log, dockside monitoring, EM data and reporting for a yearly average cost per vessel of 194 \$CND per seaday (~200 \$USD) for a British Columbia hook and line fishery. The EM only portion of that is 136 \$CND (~140 \$USD). The costs for an operational EM program along the U.S. West Coast fishery could potentially be higher or lower than this estimate depending on management requirements.

Consistent with the findings of the 2008 study, EM has been demonstrated to be an effective tool for at sea monitoring, delivering fishing effort and catch data comparable to on-board observers. There is no need for continuing to concentrate future research efforts on comparing EM data with observers. Next steps should concentrate on developing a comprehensive monitoring program involving the tools previously mentioned such as further testing of an audit-based comparison between fishing logbooks and EM with verification on retained fish from the dockside monitoring component and supplemental observers as necessary. Operationally, this will include incorporating vessel specific monitoring plans, formalized feedback protocols for both technicians and fishermen, maintaining full retention rules for rockfish, providing in season updates for fishermen, consideration of management needs, and the associated decreased risk of fishing below 200 fathoms for this fishery were all recommended.

Further work involving EM as an audit-tool should concentrate on defining the audit process. The audit framework described herein should be used as a basis for discussion on how a program of this type would work not only for just the Morro Bay fixed gear fishery, but for other fixed gear vessels and port communities that will participate in the IFQ trawl rationalization program elsewhere along the West Coast. Fisheries managers would be required to establish the requirements of the program and fishermen would then be able to engage on how to achieve those requirements. Some of the questions that require an answer from fisheries managers include: which species should be tested in the logbook audit, what is the desired turnaround time for audit results, and what should the incentives and disincentives be to achieve the desired data quality from logbook data?

TABLE OF CONTENTS

1. INTRODUCTION	1
2. MATERIALS AND METHODS	2
2.1 <i>EM Data Capture Techniques</i>	2
2.2 <i>EM Data Interpretation and Analysis</i>	5
3. RESULTS	9
3.1 <i>EM Trials on Fishing Vessels</i>	9
3.2 <i>EM Data</i>	11
4. DEVELOPMENT OF A FISHING LOG AUDIT METHODOLOGY	24
5. COST STRUCTURE CONSIDERATIONS FOR EM PROGRAMS	29
6. DISCUSSION	32
6.1 <i>Technical Assessment of EM System</i>	32
6.2 <i>Efficacy of EM for catch accounting</i>	33
6.3 <i>Efficacy of EM for Auditing Fishing Log Data</i>	35
6.4 <i>Conclusions</i>	36
REFERENCES	37
ACKNOWLEDGMENTS	39
APPENDIX I – EM TECHNICAL SPECIFICATIONS.....	40
APPENDIX II – EM DATA COLLECTED	44
APPENDIX III – SCIENTIFIC AND COMMON NAMES OF ENCOUNTERED SPECIES AND GROUPS	49
APPENDIX IV – DETAILS OF A PROPOSED FISHING LOG AUDIT METHODOLOGY ...	50

1. INTRODUCTION

In 2005, a U.S. non-governmental organization, The Nature Conservancy (TNC), purchased thirteen federal limited entry trawl-endorsed permits. Starting in 2008 TNC has licensed or leased six of these permits to up to six local fishermen to explore the economical and environmental feasibility of establishing a fixed gear fleet (longline and trap) off the coast of Morro Bay and Port San Luis, California under a community based fishing association (CBFA). In order to do so, TNC received an exempted fishing permit (EFP) each year that allowed, among other things, the use of these permits on fixed (both long line and pot/trap) gear as an alternative to trawl gear. The fishery mainly concentrated on targeting sablefish and shortspine and longspine thornyheads although the permit's quota included other catch like flatfish, dogfish, and lingcod.

As part of the EFP regulations, all fishing trips were required to carry a human observer on board to record fishing effort and catch information. Of particular importance was documenting full retention of rockfish, since the weights of all species were recorded at the time of offload to ensure that the strict hard quota caps for these species are not exceeded. A fishing logbook was also designed for the EFP, and fishermen kept fishing effort and catch records for all species retained and released on each fishing event for every trip.

The West Coast Groundfish Trawl Fishery recently implemented a new management program in January 2011 with the transition to a catch share program, also known as trawl rationalization or Individual Fishing Quotas (IFQ). Under this program, 100% observer coverage is required for all vessels in this fishery. Due to the great uncertainty surrounding the financial viability of a small groundfish fleet paying for 100% observer coverage, the EFP project proponents believed it was important to invest in and test alternative monitoring methods such as Electronic Monitoring (EM).

Over the past decade, Archipelago Marine Research Ltd. has pioneered the development of EM technology and a number of pilot studies have been carried out to test the efficacy of this technology. To date there have been over 30 studies spanning diverse geographies, fisheries, fishing vessels and gear types, and fishery monitoring issues. The capabilities of EM have been reviewed in McElderry (2008). Also, over the last six years Archipelago has been involved in the designed and implementation of an audit-based EM catch program in the British Columbia (BC) hook-and-line fishery.

TNC contracted with Archipelago to test the feasibility of implementing an EM program to monitor the Morro Bay fixed gear fishery. Archipelago had conducted a pilot study with this fishery in 2008 and the results had demonstrated EM was an effective tool for monitoring fishing effort and catch data for the Morro Bay fixed gear fishery (Pria *et al.*, 2008). This 2010 pilot study sponsored by TNC represented a unique opportunity to gain further insight on how to develop an objective, reliable and cost-effective monitoring program for a fixed gear small vessel fleet based on individual accountability EM and create a framework for how an audit-based monitoring program could be applied.

The three main objectives of the 2010 Morro Bay EM pilot study were to:

- expand the scope of data collected with EM from the Morro Bay fixed gear fishery to include more vessels and a longer time period of data collection;
- compare fishing effort and catch data from EM with observer and fishing log data; and
- create a framework on how an audit-based monitoring program could be implemented in the fishery.

2. MATERIALS AND METHODS

2.1 EM DATA CAPTURE TECHNIQUES

EM System Specifications

Six vessels participated in this study, referred to by the letters A to F in order to protect their privacy. Vessels A to D used long line gear and vessels E and F used trap pot gear to fish. Each vessel was provided with a standard electronic monitoring system consisting of a control box, a suite of sensors including GPS, hydraulic pressure transducer and/or a drum rotation sensor and up to four waterproof armoured dome closed circuit television (CCTV) cameras (Figure 1). All six vessels used hydraulic winches to haul their gear, therefore having a pressure sensor trigger the recording was the most efficient method of collecting imagery data of fishing activity. Vessel E had a pressure sensor attached to its hauler but since it also used a drum to wind the ground line on, a drum rotation sensor was placed on the vessel towards the end of the study to test if sets could be detected that way.

The control box continuously recorded sensor data (comprised of date, time, location, vessel speed hydraulic pressure, rotation sensor readings, and EM system metadata), monitored performance and controlled imagery recording according to programmed specifications, as well as provided continuous feedback on system operations through a user interface. Detailed information about the EM system is provided in Appendix I.

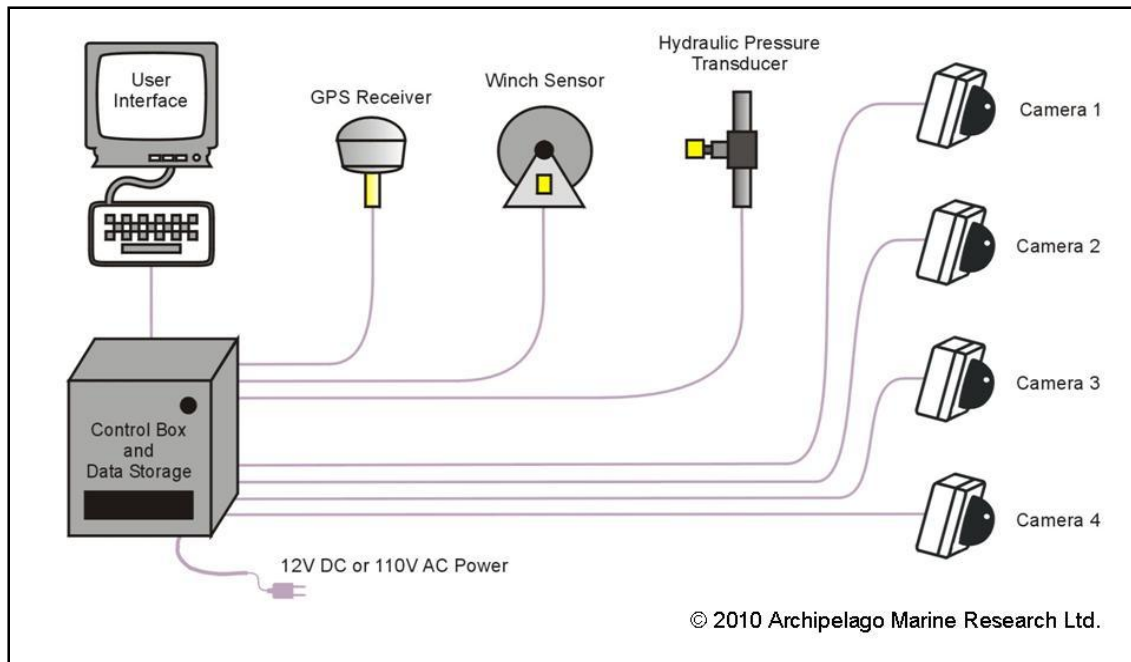

Figure 1. Schematic diagram of the electronic monitoring system, which can record video data from up to four cameras per vessel.

The EM system's GPS receiver was mounted to existing structures above the cabin away from other electronics and provided independent information on vessel position, speed, heading, and time. The electronic pressure transducer was installed on the supply side of the hydraulic system and provided an indication when hydraulic equipment (winches, pumps, lifts, etc.) were operating. CCTV cameras were mounted on each vessel in locations that provided unobstructed views of catch and fishing operations.

EM control boxes, monitors, and keyboards were mounted in a secure dry area in the vessel cabin. Sensor cables were run through bulkheads where hydraulic and electrical lines were already in place standard operation of the vessels. The control box software was designed to boot up immediately when powered on or automatically after power interruption.

EM data capture specifications

EM sensor data were recorded continuously while the EM system was powered, which was intended to be for the entire duration of the fishing trip (i.e. from the time the vessel leaves port to engage in fishing to the vessel's return to port). Sensor data were recorded every 10 seconds with a data storage requirement of 0.5 MB per day. The control box software was set up to trigger image capture when hydraulic pressure exceeded threshold levels set by the technician or the winch sensor detected rotation. Image recording ended 20 minutes after the sensor trigger ceased for all vessels and all imagery included text overlay with vessel name, date, time, and position.

Each EM system was capable of receiving video inputs from up to four CCTV cameras at selectable frame rates (i.e., images per second). Using a frame rate of 5 fps the data storage

requirement was 60–100 MB per camera per hour, equating to a system capacity of roughly 83 days of continuous recording when using three cameras and a 500 GB hard drive.

Field Operations

Planning for the EM project component began in July 2010 with a meeting in San Luis Obispo, California with by participating fishermen and staff from TNC, Tenera Environmental Ltd. (Tenera) and Archipelago. The meeting included an overview presentation of EM technology and discussions surrounding project timelines, vessel requirements, project communications, and project methodology. It was also an opportunity for Archipelago's staff to meet with the local subcontractor, Tenera, and discuss each others roles and responsibilities.

The field component began in the second week of July 2010 and continued through late December 2010. An Archipelago senior EM technician installed the EM systems on five of the vessels while training two staff from Tenera to be qualified field technicians who then installed the last Vessel in the project on their own. The EM service technician's responsibilities included the retrieval of all EM data, troubleshooting EM systems at the dock, and contacting Archipelago if any system problems arose. Staff at TNC also contributed to data retrieval from study vessels. All data collected during the project were treated with complete confidentiality.

Installations began with EM technicians and the vessel's captain discussing EM system component placement, wire routing, fishing deck operations, and the vessel's power supply. Hydraulic pressure transducers were installed on the pressure side of the hauler circuit and out of the way from vessel operations and the pressure threshold was tested. The GPS receivers were fixed to existing structures above the cabin roof, and the control box, monitor and keyboard were all secured in the vessel cabin. Due to the characteristics of the participating vessel's gear, only vessel E was installed with a drum rotation sensor in addition to a pressure sensor. This was done only for the last three trips recorded to explore if such a sensor could be used to detect gear setting by a pot gear vessel in addition to the hauling events detected by the pressure sensor installed.

Power to the EM system was supplied as 120V AC by each vessel's inverter. Upon completion of the installation, the EM system was powered up and sensors and cameras tested to ensure functionality. The skipper was also given an overview of the EM user interface and basic EM functionality. The skippers were asked to monitor the status of the EM system throughout fishing trips and left with a laminated user reference card.

Vessels participating in the pilot project carried an EM system for 6 to 28 fishing trips each. The on-site EM technician or TNC staff monitored EM system performance during data retrieval or service events between the fishing trips. Servicing included several operational checks of the equipment and retrieval of the sensor and imagery data collected. The first data retrieval was after two weeks to catch any problems with new installs quickly, after which data collection and took place every 4 weeks. Since memory requirements were relatively small for each trip, data retrieval intervals could have been extended to include up to 80 days of fishing.

During the initial service adjustments to sensor placements, threshold settings, and camera angles were sometimes necessary since sensor signatures resulting from at sea activity did not always reflect those encountered at dockside and the camera views selected did not always completely capture the activities intended. The sensor data retrieved was uploaded to a secure ftp site and imagery data were backed up on Tenera's servers for archiving and a 2.5" 1 TB external hard drive for shipping. The 1 TB hard drive was packaged and sent back to Archipelago's head office in Victoria, BC every other month.

2.2 EM DATA INTERPRETATION AND ANALYSIS

Data interpretation protocols were designed and communicated to the data technicians involved in the study before any of the data were processed and were based on the study's objectives, project methodology talks during the project planning stage, and experience accumulated from similar studies carried out in the past. Sensor data interpretation was carried out before image interpretation to access imagery from haul start times directly without having to review all of the imagery for a trip. The observer and fishing log data were not received until all of the EM data were interpreted to ensure unbiased interpretation.

Staff at Tenera was trained in the use of EM Interpret (EMI) and Video Analyser, two pieces of proprietary software created by Archipelago for interpreting the data collected by EM systems. The sensor and image data interpretation, described below, was performed almost exclusively by two part time staff hired from the local university campus as a way of providing opportunities and expanding the pool of skilled labour in the area. After the first couple months of the project, a series of work orders for the six Vessels were also reviewed by experienced viewers at Archipelago's headquarters in Victoria, BC, Canada as a form of QA/QC and the results were disseminated via an internal document.

Sensor Data Interpretation

All of the sensor data collected during the project were interpreted. Sensor data were imported into EMI and analysed to determine the completeness of each data set by checking for time breaks in the data record, as indicated by the duration between records exceeding the expected 10-second time interval. Sensor data were then analysed to interpret the geographic position of fishing operations and distinguish key vessel activities including transit, gear setting, and gear retrieval.

EMI facilitated sensor data interpretation as illustrated in Figure 2. Vessel speed and hydraulic pressure often correlate uniquely for various activities such as transit, setting, and hauling. Gear setting is indicated by medium vessel speed with a constant heading for a short period of time while on the fishing grounds and an absence of hydraulic pressure readings, usually preceded by a sharp turn or circle. Gear hauling is typically indicated by a spike in hydraulic pressure and a very slow speed, but the track of the vessel may or not be straight as the line is pulled in. Sets and hauls were defined as extending from the first float to the last float. The spatial plot provided a perspective on the various activities in relation to one another and was useful to help associate specific setting and hauling events. Setting and hauling events were matched to each other by interpreting physical proximity and timing. When displayed in this manner, the analyst reviewed the trip, interpreted vessel activity, and made annotations in the sensor record for haul and setting

events. Haul start and end times from sensor data interpretation provided an initial reference for accessing image data. Catch assessments were only performed for hauls which we had complete data for, since comparing results from incomplete imagery data would obviously return erroneous findings.

Part of the sensor data interpretation also involved the evaluation of the EM system sensors. The electronic pressure transducer and drum rotation sensor signals were evaluated for completeness throughout each trip. The quality of the GPS receiver was evaluated to determine reliability of position and time signal. Poor GPS receiver signal is usually the result of an intermittent GPS signal caused by interference or a large satellite error in determining position. For each trip, each sensor's signals were rated as follows:

- Complete. The sensor performed to its full capacity.
- Incomplete. The sensor experienced intermittent failures or false readings.
- No data. The sensor did not operate during the trip.

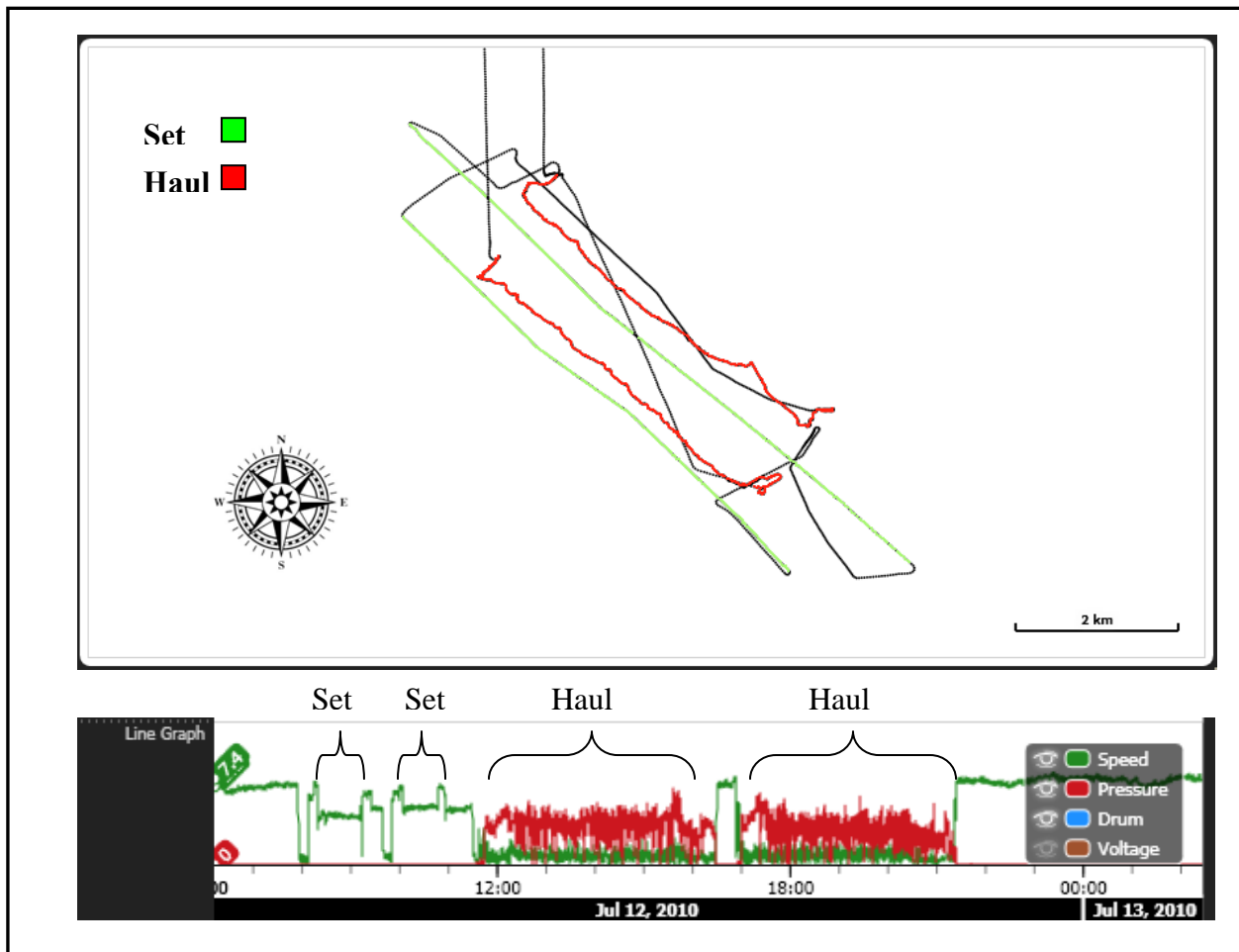

Figure 2. Example of sensor data from one of the project vessels for a trip. The time series graphs (lower) show vessel speed (knots), and hydraulic pressure (psi). Setting activity for horizontal longline was associated with constant and relatively high speed, relatively constant heading, and physical proximity to a haul.

Hauling for horizontal longline was associated with high hydraulic pressure and relatively low speed. The spatial plot (upper) shows the vessel's cruise track for the same period, with setting highlighted in green and hauling in red.

Image Data Interpretation

Image data were interpreted using Video Analyser, a proprietary software product that provided synchronised playback of all camera images and a data entry form for recording catch observations in a sequential manner. This application outputted the catch composition data in XML files that were then loaded into a relational database for the catch comparison analysis between EM and observer and fishing log data.

Since catch data can only be compared across different data sources for complete fishing events, image data interpretation was done for all hauls captured completely by EM. The first step of image interpretation was to assess whether all the intended imagery was recorded properly. This was achieved by comparing the haul start and end times from the sensor data with those available for image data. The hauls that were deemed to have complete imagery were reviewed for catch assessment and image quality.

The EM data technicians counted and identified target and non-target catch to the lowest taxonomical grouping possible and also kept track of catch disposition. EM catch disposition data included: retained, released, and drop-off (catch that fell off the gear before the fisherman had control over it).

Image quality was assessed as an average for each haul event viewed, according to the rank scale illustrated in Figure 3 and defined as follows:

- **High.** The imagery was very clear and the viewer had a good view of fishing activities. Focus is good, light levels are high and all activity is easily seen.
- **Medium.** The view was acceptable, but there may be some difficulty assessing discards. Slight blurring or slightly darker conditions hamper, but do not impede analysis.
- **Low.** The imagery is difficult to assess. Some camera views may not be available. Imagery is somewhat blurred or lighting has largely diminished. Some factors such as the fishing line going out of camera view or crew standing between the catch and the camera for extended periods of time may have also occurred.
- **Unusable.** The imagery is poorly resolved or obstructed such that fishing activity cannot be reliably discerned.

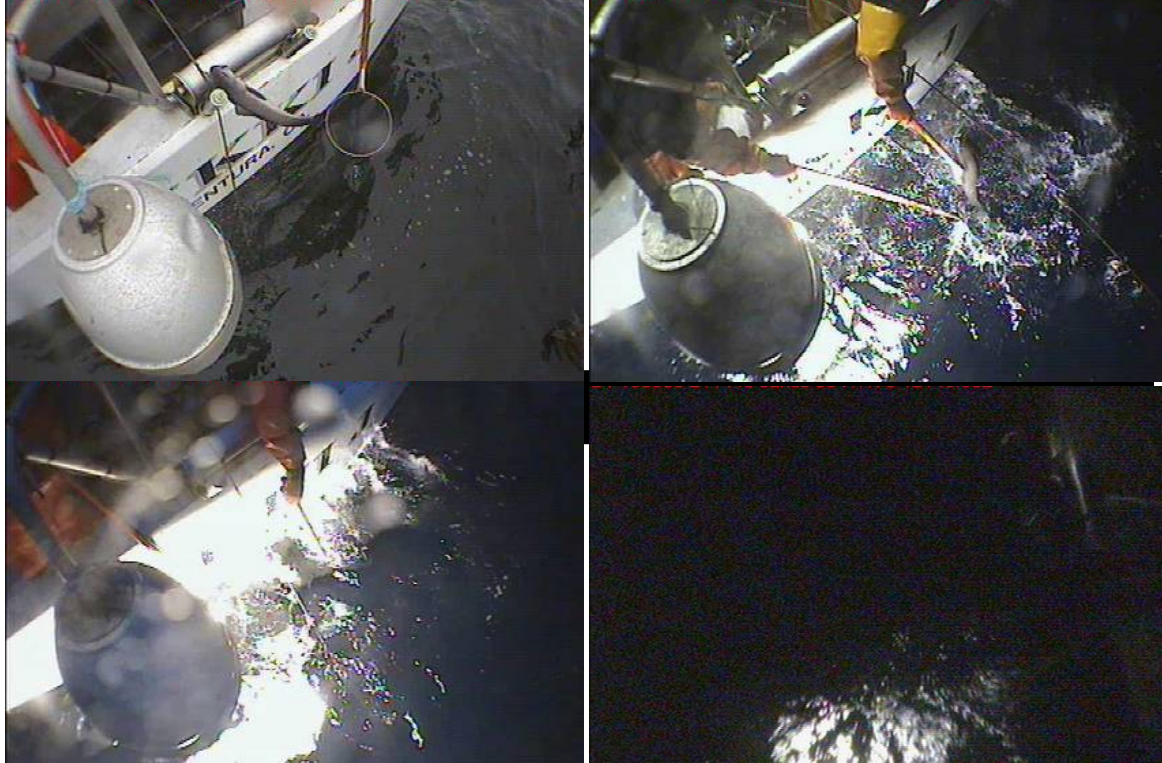

Figure 3. Example imagery to illustrate the different image quality assessments. From left to right, top to bottom: high, medium, low and unusable. Image quality is determined as an average of all cameras throughout an entire haul. Some cameras may yield a better angle and image clarity than others within the same haul but it is the overall ability to meet imagery review objectives that ultimately determines the imagery quality rating.

Data Analysis

Data checks were in place throughout the data interpretation steps and mainly involved the use of validation rules with minimal ad-hoc double-checking of some data. The data analysis itself was done once all of the sensor and image data were interpreted.

The data processing, tracking and management was done using Excel while the data outputs from all sources (sensor, imagery, observer data, and fishing log data) were available in relational databases allowing all the data analysis to be carried out using an MS Access database.

As one of the main goals of the study was to compare EM, observer, and fishing log estimates of catch species, it was important to appropriately match the three data sets. Fishing event matching between observer, fishing log and EM was done using the set start and haul end date and time as determined by each data source.

As part of the standard QA/QC process, a selection of EM imagery was viewed by a second data technician and the results were compared with both the EM and observer results used in this report. Fish counts and species identifications used in this report are referred to as “EM data” or “primary” and data resulting from secondary data technician review is referred to as “secondary”. The hauls reviewed were not chosen at random, as is typically done, but

represented a 10% sample size of the hauls for each boat that focused on the greatest percentage mismatches between EM and observer total counts by haul to focus on problem areas.

3. RESULTS

3.1 EM TRIALS ON FISHING VESSELS

EM System Deployments and Data Captured

EM system deployment results are summarized in Table 1 and completely displayed in Appendix II due to the volume of data for 6 vessels. The data collection for the pilot study spanned a five and a half month period and each vessel completed between 6 and 28 fishing trips for a total of 125 days at sea. Every vessel carried an observer and filled out a haul by haul fishing logbook for every trip to allow data comparisons between the three sources. EM collected a total of over 2729 hours of sensor data at sea, and 762 hours of haul imagery associated with 332 fishing events.

The overall sensor data capture success was 91%, ranging from 4% to 100% per trip (two trips had 4% and 8% data capture and the rest had over 65%). Gaps in the sensor data record occurred most commonly during the vessel’s initial or final transit from the fishing grounds to port.

Table 1. Summary of EM data collected by vessel.

Vessel ID	Number of Trips	Data Collection Period	Days at-sea	Sensor Data Collected (Hours)	Sensor Data Complete (%)	Haul Imagery Collected (Hours)	EM Detected Hauls
A	28	12 Jul to 24 Dec	28.7	654.1	95%	182.2	63
B	24	21 Jul to 23 Dec	26.5	516.7	81%	171.3	29
C	14	7 Jul to 31 Oct	18.8	450.7	100%	150.8	39
D	14	14 Jul to 7 Oct	19.2	410.4	89%	124.2	30
E	11	26 Jul to 25 Sep	17.1	399.3	97%	43.4	67
F	6	14 Jul to 20 Aug	14.4	297.9	86%	90.9	104
Totals	97		124.6	2729.1	91%	762.7	332

Sensor performance was high across all vessels (Table 2) with the hydraulic and drum rotation sensor working properly for 100% of the trips where they were installed and the GPS providing complete data for 95 of 97 trips. The two trips where there was a loss of GPS data (i.e. location and speed) occurred in a single vessel. In one instance GPS data was available for 16% of the trip but positional information was available for 2 of 3 hauls (classified as incomplete data). In the other instance GPS data was available for 23% of the trip but only during the transit to port with no location for the fishing event available (classified as ‘no data’). GPS errors in these two trips did not impact imagery data triggering or detection of sets and hauls in the sensor data.

Table 2. Summary of sensor performance for all trips throughout the pilot study.

Vessel ID	GPS	Drum Sensor	Hydraulic Sensor
Complete	95	3	97
Incomplete	1	0	0
No Data	1	0	0
Not Installed	0	94	0
Totals	97	97	97

Table 3 shows the total number of hauls recorded by the observer and fishing log for each trip and the EM capture success for them. Observer data were collected for a total of 286 hauls, fishing log data for 338 hauls and 332 hauls were detected by EM and where hauls matched between either EM and observer or EM and fishing log data, comparisons were performed. Observers did not differentiate individual hauls for three multiday trips on Vessel F, recording one event per day instead for a total of 7 events. Fishing log and EM recorded individual hauls resulting in a large total haul difference between these and observer data. Six hauls were not captured by EM due to power interruption to the system which explains the remaining differences between hauls recorded by each data source. Five of the non-captured hauls corresponded to the same trip in which the EM system was only powered for 1.4 hours at the fishing grounds. The remainder non-captured hauls occurred in Vessel F.

Hauls were considered to be complete when EM data (sensor and imagery) were available for review for the entire haul. Only hauls with complete EM sensor data could be compared, as the incomplete hauls would have resulted in inconclusive catch comparisons. Vessel B had two hauls with time gaps at the start or end so only had 27 of 29 hauls detected complete, while Vessel F had one haul with a time gap at the end. This resulted in 329 of the 332 hauls that EM detected being classified as complete for further analysis.

Table 3. Summary of hauling events captured by observer, fishing log and EM.

Vessel ID	Trips	Observer Recorded Hauls	Fishing Log Recorded Hauls	EM Detected Hauls	EM Sensor Data Complete
A	28	63	63	63	63
B	24	30	30	29	27
C	14	39	39	39	39
D	14	35	35	30	30
E	11	67	67	67	67
F	6	52	104	104	103
Totals	97	286	338	332	329

Note: For vessel F, OBS recorded hauls by day rather than discreet events during some trips, thus the final event count was much lower.

Table 4 shows the total number of hauls with complete and usable video data and how many had catch records compared to observer and fishing log recorded hauls. Imagery data from one haul on Vessel B could not be used due to poor lighting during a night haul. This resulted in EM data being used for catch comparisons for a total of 328 hauls. The 328 hauls with usable video data had to be lined up with the corresponding haul entries from the observer (n=286) and fishing log

(n=338) data in Table 3. When this was done, there were 276 comparisons between EM and observer data and 328 comparisons between EM and fishing log data.

The different approach for recording hauls for three trips for Vessel F resulted in 58 EM hauls being summed by day and compared to 7 observer entries. To further complicate matters, one of those days contained a haul that was missed by EM. Since no catch data was available for that haul, it created a situation where the other six EM hauls in that day had to be disregarded from further analysis. This is why the number for EM imagery data to observer data comparisons for Vessel F (and the grand total) is 51, much less than the total number of usable hauls from EM imagery.

Table 4. Imagery data totals based on Sensor data complete events (n=329)

Vessel ID	EM Imagery Data Complete	EM Imagery Data Usable	EM Imagery Data Unusable	EM Imagery Data to Observer Comparisons	EM Imagery Data to Fishing Log Comparisons
A	63	63	0	63	63
B	27	26	1	26	26
C	39	39	0	39	39
D	30	30	0	30	30
E	67	67	0	67	67
F	103	103	0	51	103
Totals	329	328	1	276	328

Aligning EM hauls with observer and fishing log data was mostly based on date and time of the hauls. However, this had to be manually verified due to inconsistencies in observer and fishing log data, as some haul information related to the beginning of the haul and the rest related to the start of the haul.

3.2 EM DATA

Interpretation of EM sensor data

The interpretation of EM sensor data was based on recognizing ‘signatures’ in the data collected. One of the most obvious was the high constant speed and lack of pressure sensor associated with a vessel transiting to and from the fishing grounds. While there are slight variations from vessel to vessel, hauling events were characterized by high hydraulic pressure and relatively low vessel speed, with both pressure and speed tending to fluctuate corresponding to work associated with catch retrieval. There were no specific sensors capable of detecting setting events since the vessels set the gear by hand directly from tubs. However, the combination of relatively high and constant speed, consistent heading, and geographical proximity to the haul was a reliable way to determine setting for horizontal long line events. Trap sets were often very hard to determine when they did not occur within the same fishing trip but EM data was used on occasion as supplemental information to link sets to hauls from the fishing logbooks by TNC.

Interpretation of EM imagery data

Image quality ratings for all 328 usable hauls are shown in Table 5. Image quality was rated as high or medium for 96% of the hauls reviewed and while there is a distinction made between high and medium quality video imagery, they both provide the ability to count, speciate and assign utilization to catch items. Low image quality was assigned to 4% of the hauls analyzed due to increased difficulties keeping track of catch dispositions as well as lower than usual image clarity for the purpose of speciation. Low image quality ratings were mostly due to back lighting from deck lights and camera pixilation during night hauls.

Table 5. Summary of EM imagery data quality assessments.

Vessel ID	High	Medium	Low	Total
A	13	47	3	63
B	3	21	2	26
C	19	19	1	39
D	3	21	6	30
E	0	67	0	67
F	97	4	2	103
Totals	135	179	14	328

Image playback speeds during interpretation varied from about 0.5 to 4 times real time according viewer experience, catch density, and image quality. Average viewing analysis ratios are shown in Table 6 and expressed as the length of the haul divided by how long it took to review the associated video. While the overall viewing ratio for the project was 0.59, for long line vessels the average ratio was 0.66 (range: 0.47 to 0.76) and for pot/trap vessels the average ratio was 0.31 (range: 0.28 to 0.33). Trap pot boats have a noticeably lower viewing ratio due to the very long interval between the first float and the first pot not needing to be watched for catch handling and all the fish coming aboard relatively quickly in a gang of fish pots. Imagery review was most efficient when image quality was high or medium, fish came on board one by one and always in camera view, fish handling on board was consistent, and discarding took place in camera view and in a way that facilitated piece counting. Hauling fish partially out of the close up camera view, gear tangles, inconsistent fish sorting, and fish discarded partially outside camera view and/or en mass required imagery playback to be slowed down or paused and rewound to minimize the likelihood of missing something.

Table 6. Summary of EM imagery viewing and hauling times

Vessel ID	View Time	Haul Time	Average Viewing Ratio
A	141.75	186.38	0.76
B	76.20	160.61	0.47
C	102.80	150.79	0.68
D	91.92	124.21	0.74
E	21.43	65.29	0.33
F	25.50	90.39	0.28
Totals	459.60	777.67	0.59

Comparison of EM and Observer Catch Observations

Catch comparisons between EM and observer data (Table 7) were done for the 276 hauls that were comparable with observer records. From these hauls, observer and EM fish catch data were compared across of a total of 39 catch categories including 28 species, 1 genus, 7 families, 1 class and 1 category for 'unknown fish'. The more general classifications to genera and unknown categories by EM correspond to a lower ability to speciate some catch compared to the observers.

Similar to the 2008 EM study, EM did not attempt to distinguish between 2 species of thornyheads (*Sebastolobus spp.*) as previous experience has shown that the confidence in this identification is very low. Due to this, observer entries for shortspine (*Sebastolobus alascanus*) and longspine (*Sebastolobus altivelis*) thornyheads were grouped for comparison to EM. EM interpreters attempted to speciate all other catch.

The overall fish catch comparison between observer data and imagery data shows catch by species (or species categories) and two indices of abundance. Percent occurrence reflects the percentage of analyzed hauls where the species were detected and gives an idea of how common a species is. Table 7 also shows total pieces as recorded by observer and EM along with the total piece difference (observer pieces - EM pieces) and a percent difference calculated as (observer pieces - EM pieces)/observer pieces. This percent difference value is only shown if the number of observer pieces was greater than 50 to prevent arbitrary inflation of the percentage in small samples. Displaying both percent occurrence and total number of pieces allows the reader to calculate the average number of pieces per haul for any given species or group. Only the most common fish species are listed in the table and all others are shown as species group totals for general comparison purposes. A table with all the associated species names can be found in Appendix III.

Both observer and EM data contained over 105,000 total fish catch items with sablefish (*Anoplopoma fimbria*) being the most common species in both data sets, followed by thornyheads (*Sebastolobus spp.*). Most importantly, overall EM data contained only 1% less catch items than observer data.

For target catch, there was high level of agreement between observer and EM piece count data for sablefish with EM having 1% less, and overall rockfishes (*Sebastes* and *Sebastolobus sp.*) with 3% less difference (observer-EM). This is especially important, since they are highly valuable market and conservation species respectively. There were however differences in total pieces by species category for both sharks, flatfishes and 'other' fish.

EM detected 8% more skates than observers and of those it did identify, EM could only confidently speciate about 50% of them, failing to spot sandpaper skates (*Bathyraja interrupta*) as in the observer data. Speciation for sharks was not consistent in the two data sets either, with EM greatly over representing brown cat sharks and failing to detect three species of shark identified by the observer. This created a 17% difference in count between observer and EM data at the total sharks level.

While EM categorized just over 1000 catch items as unknown fish, this accounted for only 1% of all EM records. Most of these catch items were hard to identify due to either night hauls (especially dusk/dawn fishing on Vessel D or crew blocking the field of view).

Table 7. Summary table showing the comparison of observer and EM total catch by species or species group.

Species Name	Obs Percent Occurrence	EM Percent Occurrence	Obs Pieces	EM Pieces	Total Piece Difference	Percent Difference
Thornyheads *	65%	59%	12,906	12,074	832	6%
Blackgill Rockfish	9%	1%	696	43	653	
Aurora Rockfish	9%	0%	107	0	107	
Chilipepper Rockfish	0%	0%	1	0		
Pinkrose Rockfish	0%	0%	1	0		
Rosethorn Rockfish	0%	0%	1	0		
Rockfish (unidentified)	0%	23%	0	1,117	-1,117	
Total Rockfish			13,712	13,234	478	3%
Sablefish	100%	100%	83,872	82,834	1038	1%
Dover Sole	54%	4%	579	55	524	
Deepsea Sole	0%	0%	2	0	2	
Flatfish (unidentified)	0%	47%	0	408	-408	
Total Flatfish			581	463	118	20%
Filetail Cat Shark	41%	0%	5,518	0	5,518	
Longnose Cat Shark	17%	0%	359	0	359	
Brown Cat Shark	7%	0%	60	166	-106	
Cat Sharks	0%	46%	0	4,772	-4,772	
<i>Total Cat Sharks</i>			<i>5,937</i>	<i>4,938</i>	<i>999</i>	17%
Spiny Dogfish Shark	15%	6%	89	28	61	
Sharks (unidentified)	6%	11%	35	68	-33	
Blue Shark	5%	2%	31	6	25	
Pacific Sleeper Shark	1%	5%	4	19	-15	
<i>Total Other Sharks</i>			<i>159</i>	<i>121</i>	<i>38</i>	24%
Total Sharks			6,096	5,059	1,037	17%
Longnose Skate	39%	7%	1,322	215	1,107	
Black Skate	10%	0%	164	8	156	
Sandpaper Skate	7%	0%	89	0	89	
Skate (unidentified)	1%	42%	14	1,488	-1,474	
Total Skates			1,589	1,711	-122	-8%
Pacific Grenadier	9%	0%	660	0	660	
Giant Grenadier	14%	1%	239	25	214	
Grenadier (unidentified)	2%	14%	16	681	-665	
California Grenadier	1%	0%	6	0	6	
Popeye Grenadier	0%	1%	0	97	-97	
<i>Total Grenadiers</i>			<i>921</i>	<i>803</i>	<i>118</i>	13%
Unknown Fish	0%	46%	0	1,076	-1,076	
Total Other Fish			921	1,879	-958	-104%
Overall Totals			106,771	105,180	1,591	1%

* Thornyheads are grouped in this table as EM did not differentiate shortspine and longspine thornyheads. However, observer data had these species broken down and included one piece of longspine thornyhead.

On the basis of individual fishing events, the scatter plot shown in Figure 4 indicates that for almost every haul there was a very close agreement in the total number of pieces between observer and EM. This is despite there being two distinct gear types (and hence catch handling procedures) and three orders of magnitude change in total catch. When comparing EM to observer counts, there would ideally emerge a 1:1 ratio of counts over a great number of hauls. While this trend is achieved for the most part, there is the complication of comparing piece counts that range from single to triple digits per haul. For hauls that contain over 30 pieces of fish (regardless of species) using percentages makes sense, while for hauls with smaller piece counts using the difference is more appropriate (For context: 2 fish are 2% of 100 fish but 50% of 4 fish).

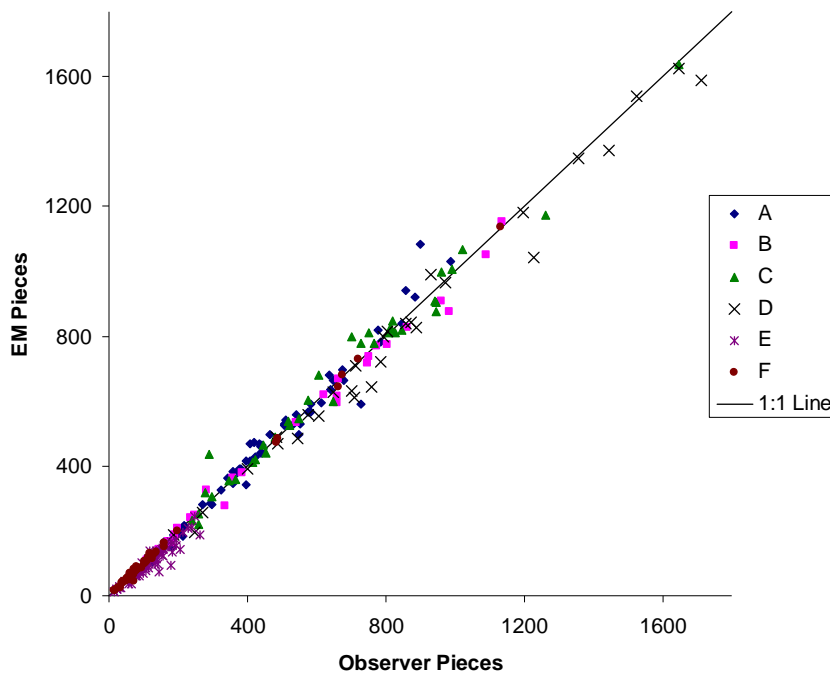

Figure 4. Scatter plot of observer data total catch versus EM data total catch per fishing event showing all Vessels and hauls. Only fish species were considered for this analysis.

Piece count differences by selected species and species categories at the haul level follow the trends seen in the total catch results (Figure 5). As the most important market species, Sablefish were very important to the fishery and piece count differences between EM and observer data show a very high level of agreement, with EM piece count being 3.76 pieces less than observer average of 304 fish per haul. Rockfish are an important species for conservation reasons and EM was accurate at reporting them, only under reporting an average haul of 75 fish by 2.72 pieces.

Sharks and flatfish were all slightly underrepresented by EM. Shark piece counts were 7.86 under the average observer count of 42 and flatfish were 0.78 pieces under the average observer count of 4 per haul. Skates were recorded by EM more often than by observers (0.98 more skates per average haul of 13) and seen on 125 of 328 hauls. The category for ‘other’ fish held a variety of species, including, but not limited to, Grenadiers, Hagfish, Ratfish and unknown fish. Despite the wide variety of species, EM tended to over represent this group by 3.67 fish per average haul

of 16. The bulk of this category was the 'unknown fish' group at close to 50% of the piece counts.

Observers and EM image viewers used slightly different categories for catch disposition when catch was not retained. Observers recorded non-retention disposition as 'Released', whereas viewers categorized non-retention either as 'Released' or 'Drop-off'. The 'Drop-off' disposition was given to catch that dropped off the gear before the fisherman had taken control of that particular catch item. Due to the differing detail in non-retained catch, catch disposition was compared after grouping EM "drop off" and "released" catch. Observer data recorded 87% of the fish catch as retained. Catch disposition comparisons of EM and observer data for total fish catch per haul are shown in Figure 10. EM slightly over-represented retention and underrepresented non-retention. Most of the outliers in the non-retained graph correspond to non-target species that EM detected when it was brought onboard, but was not detected when discarded. The discrepancy between discarded numbers for EM and observers may be inflated visually by the scale of the second graph and readers should keep in mind that the overall piece count for all species and vessels only differed by 2%.

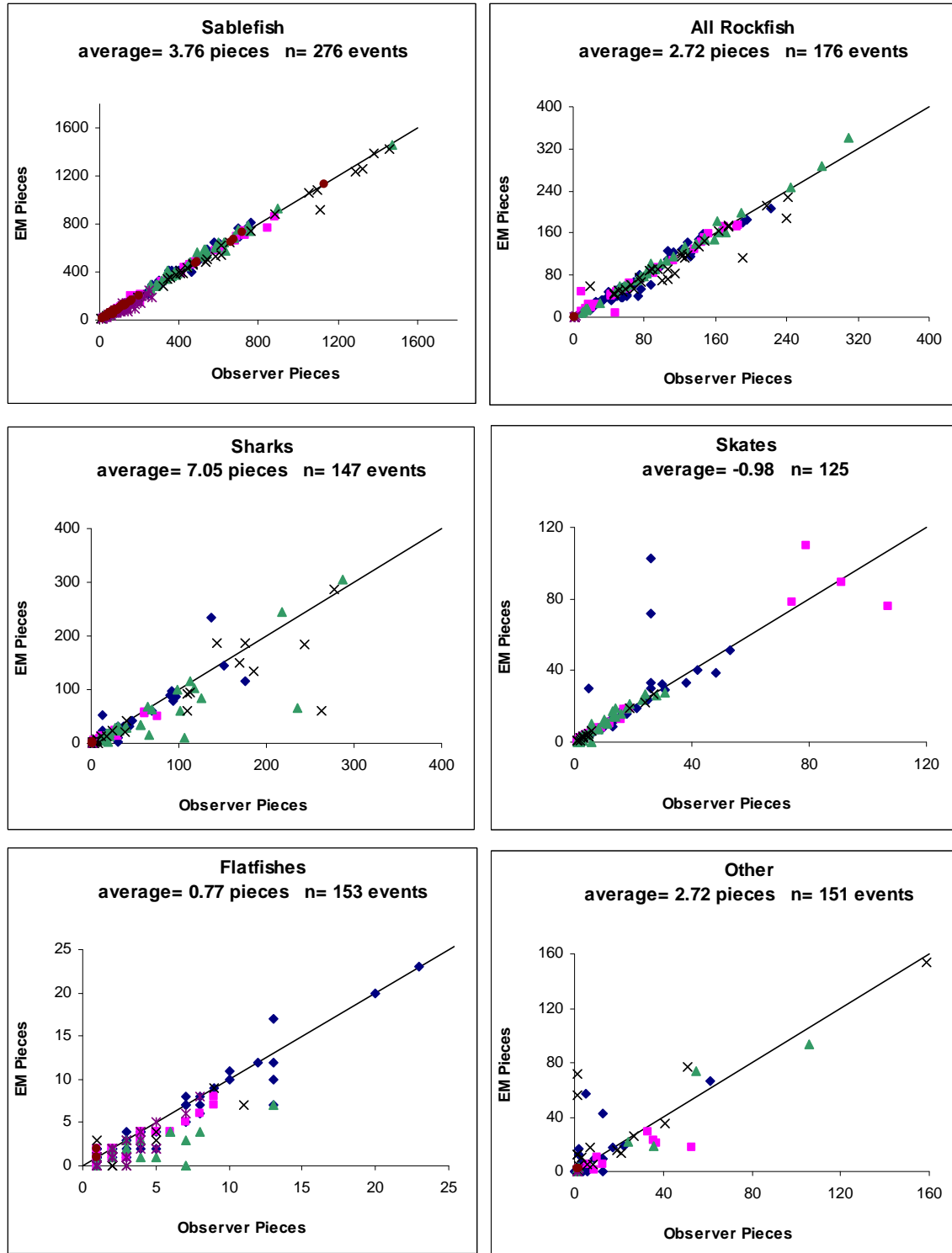

Figure 5. Scatter plots for EM data catch versus observer data total catch per fishing event for Sablefish, the most common target species, grouped rockfish and the most common bycatch species group. Each plot also shows the average observer minus EM piece difference and the total number of events compared for each species or species group. Legend for Vessel symbols is the same as Figure 4.

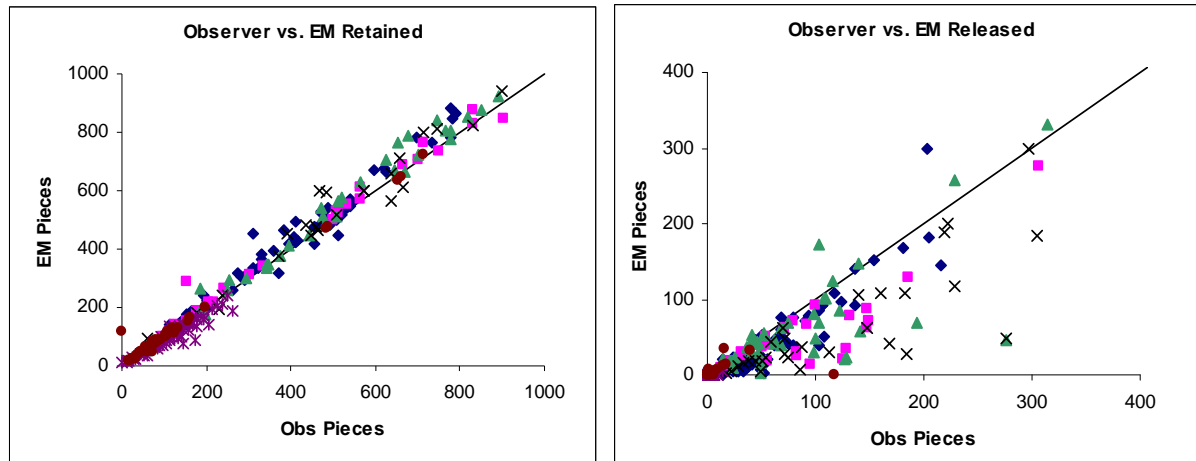

Figure 6. Scatter plot of retained and non-retained observer data total fish catch per haul versus EM data total catch per haul. The legend is the same as Figure 4.

Catch Comparison of EM and Fishing Log Observations

In the 328 events compared between EM and fishing log data, fishing logs categorized catch into 23 species, 1 genus, 7 families, 1 class and 1 unknown fish category. This was quite similar to the species list of the observer to EM comparison, except there were five fish species that observers speciated that fishers did not. The more general classifications by EM correspond to rockfish and flatfish species, while fishing log data assigned more general categories to bycatch species.

Table 8 shows the total piece comparison between EM and fishing log data (here it is calculated as ‘EM – fishing log’ since that is how an audit would work) by species or species category. Again the comparisons overall were good and fishing log data contained 0% different fish catch items and 1% more and 4% less items for sablefish and rockfishes respectively. Fishing log counts for flatfish, skates and sharks were less in line with EM counts, at 9% more, 13% less and 14% more respectively. Again, EM was not able to identify about 1% of the catch that was identified in the fishing log and grouped them to unidentified fish. While it is tempting to re-allocate those fish to the missed shark category, they could in fact be from any of the species listed.

Table 8. Summary table showing the comparison of fishing log and EM total catch by species or species group. (n= 328)

Species Name	FLog Percent Occurrence	EM Percent Occurrence	FLog Pieces	EM Pieces	Total Piece Difference	Percent Difference
Thornyheads *	51%	50%	11,908	12,074	166	1%
Blackgill Rockfish	8%	1%	666	43	-623	
Aurora Rockfish	7%	0%	98	0	-98	
Chilipepper Rockfish	0%	0%	1	0	-1	
Pinkrose Rockfish	0%	0%	1	0	-1	
Rosethorn Rockfish	0%	0%	1	0	-1	
Rockfish (unidentified)	0%	19%	0	1,117	1,117	
Total Rockfish			12,675	13,234	559	4%
Sablefish	100%	100%	83,930	83,330	-600	-1%
Dover Sole	42%	4%	506	55	-451	
Deepsea Sole	0%	0%	0	0	0	
Flatfish (unidentified)	0%	40%	0	408	408	
Total Flatfish			506	463	-43	-9%
Filetail Cat Shark	0%	0%	0	0	0	
Longnose Cat Shark	0%	0%	0	0	0	
Brown Cat Shark	0%	1%	0	166	166	
Cat Sharks	0%	39%	0	4,772	4,772	
<i>Total Cat Sharks</i>			<i>0</i>	<i>4,938</i>	<i>4,938</i>	
Spiny Dogfish Shark	13%	5%	759	28	-731	
Sharks (unidentified)	39%	9%	5,006	68	-4,938	
Blue Shark	0%	2%	0	6	6	
Pacific Sleeper Shark	0%	5%	0	20	20	
<i>Total Other Sharks</i>			<i>5,765</i>	<i>122</i>	<i>-5,643</i>	
Total Sharks			5,765	5,060	-705	-14%
Longnose Skate	0%	6%	0	215	215	
Black Skate	0%	0%	0	8	8	
Sandpaper Skate	0%	0%	0	0	0	
Skate (unidentified)	36%	35%	1,494	1,488	-6	
Total Skates			1,494	1,711	217	13%
Pacific Grenadier	3%	0%	377	0	-377	
Giant Grenadier	0%	1%	0	25	25	
Grenadier (unidentified)	15%	12%	383	681	298	
California Grenadier	0%	0%	0	0	0	
Popeye Grenadier	0%	1%	0	97	97	
<i>Total Grenadiers</i>			<i>760</i>	<i>803</i>	<i>43</i>	5%
Pacific Flatnose	0%	1%	0	18	18	
California Slickhead	5%	0%	260	0	-260	
Pacific Hagfish	0%	1%	0	3	3	
Hagfish (unidentified)	11%	3%	49	12	-37	
Pacific Pomfret	1%	0%	24	1	-23	
Spotted Ratfish	1%	1%	3	4	1	
Pacific Hake	0%	1%	0	20	20	
Unknown Fish	0%	38%	1	1,076	1,075	
Lamprey	0%	0%	0	1	1	
Total Other Fish			1,097	1,938	841	43%
Overall Totals			105,467	105,736	269	0%

* Thornyheads are grouped in this table as EM did not differentiate shortspine and longspine thornyheads.

Total catch by haul comparisons are shown in Figure 7. The average EM minus fishing log piece difference for all vessels is 0.16 pieces or 0% of the average number pieces (322) per event. One outlier was identified in the total catch per event comparisons and was displayed with a red circle on Figure 7. This outlier corresponding to vessel C was the result of a haul total difference of 150 fish that were classified as ‘unknown’ by EM when none were recorded by the fishing log.

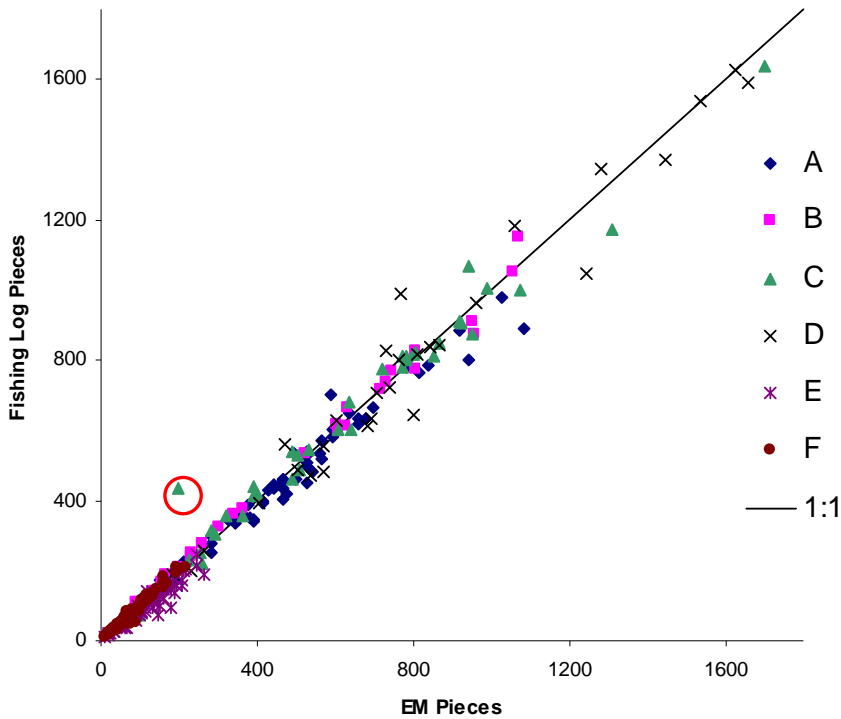

Figure 7. Scatter plot of EM versus fishing log data total catch per haul. Only fish species were considered for this analysis. Outliers displayed with a red circle are described in the text.

Similar to the EM to observer comparisons, piece count differences by species (Figure 8) for fishing logs to EM (EM – Flog) at the haul level also follow the trends seen in the total catch results. There was very high agreement between fishing log and EM piece counts for sablefish and rockfishes, with sablefish within 1% of the average number of pieces per set and rockfishes 3.23 pieces lower than the average haul size of 39. Sharks, skates and flatfishes were all very close, being 0.25 and 1.32 fish higher and 0.32 fish lower for an average haul respectively. While the panel for ‘other’ fish show a much larger difference between fishing logs and EM, the average difference of 4.68 pieces is greatly inflated by only a few hauls.

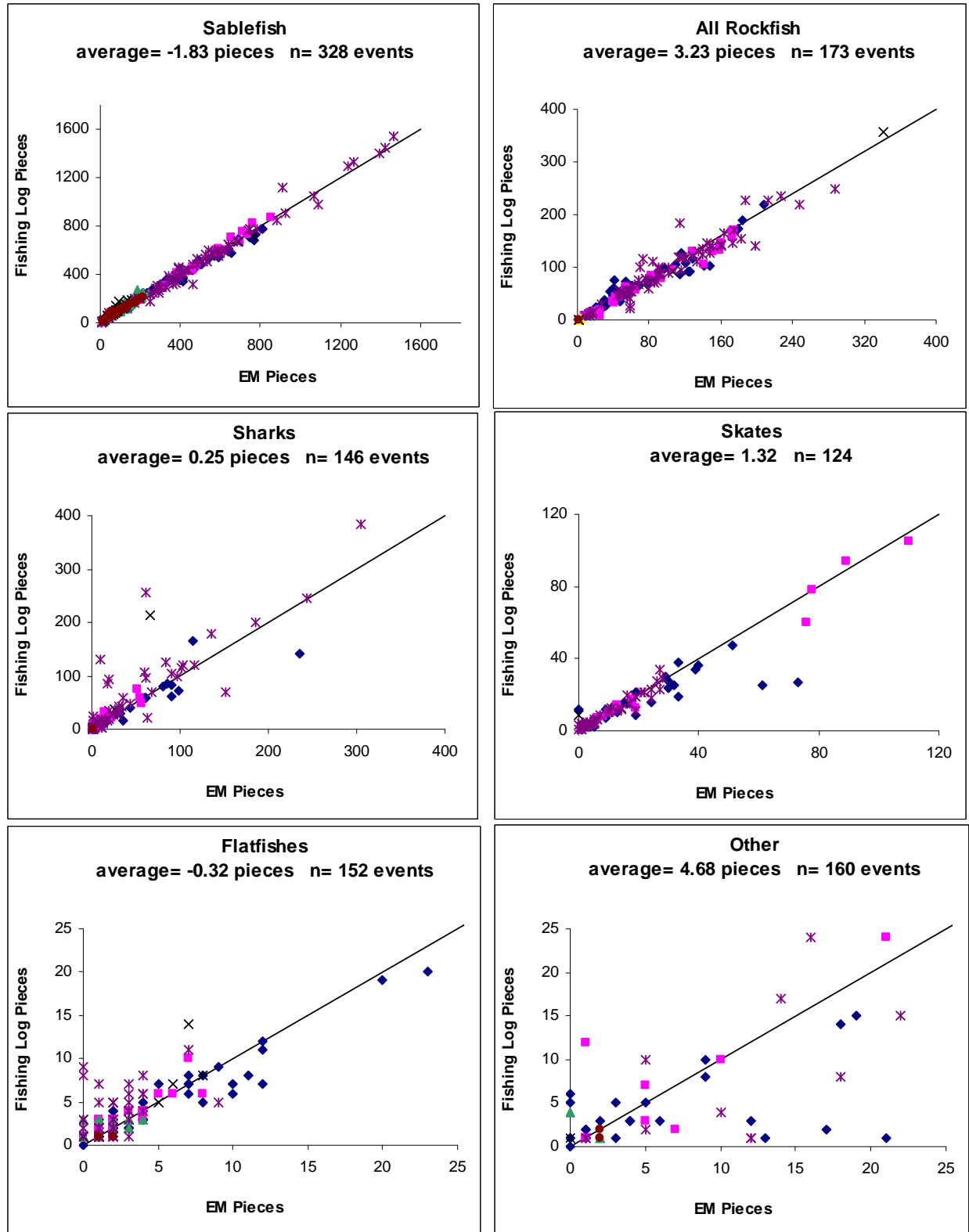

Figure 8. Scatter plots for fishing log data catch versus EM data total catch per fishing event for sablefish, grouped rockfish, and the most common bycatch species groups. Each plot also shows the average EM minus fishing log piece difference and the total number of events available for each comparison. The legend is the same as Figure 7.

Catch disposition comparisons of EM and fishing log data for total fish catch per haul are shown in Figure 9. Fishing log data recorded 90% of the fish catch as retained while EM recorded 91% as retained. EM slightly over-represented retention and underrepresented non-retention. Most of the scatter in the non-retained graph corresponded to bycatch that EM detected when it was brought onboard, but was not detected when discarded as it was discarded by observers outside of camera view. Discrepancies between discarded numbers for EM and fishing logs may be inflated visually by the scale of the second graph and readers should keep in mind that the overall piece count difference between EM and fishing logs for all species and Vessels was 0%.

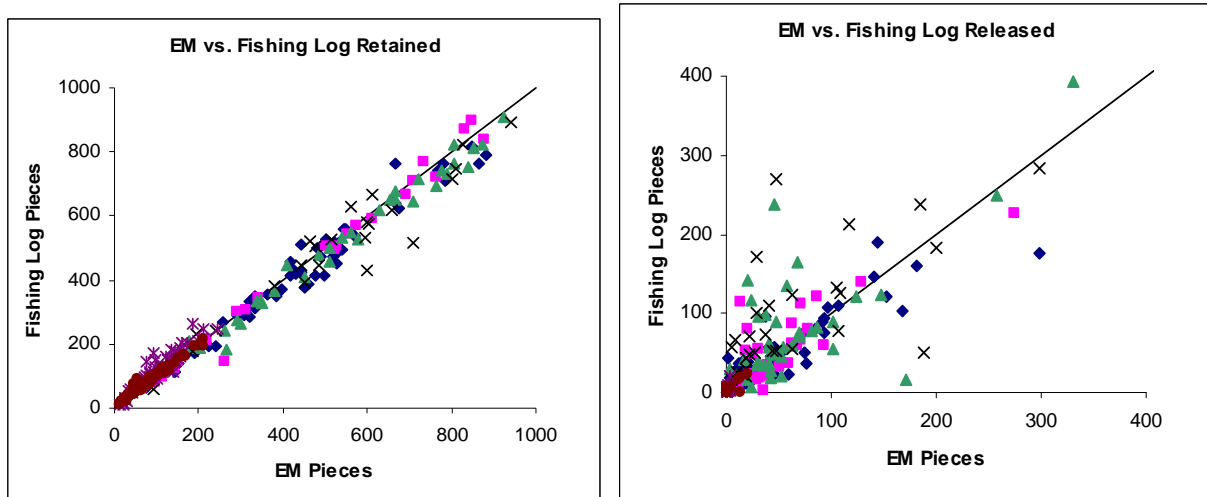

Figure 9. Scatter plot of retained and non-retained fishing log versus EM data for total fish catch per haul. The legend is the same as Figure 7.

Viewer Comparison and Quality Control

Twenty-six hauls were reviewed a second time by experienced viewers at Archipelago. Of that sample, only 1 was rated low quality for viewing. Two questions were asked when comparing the primary and secondary viewing data: 1) Compared to observer data, did secondary viewing improve on the data from that of primary viewing. Here we use ‘improved’ to mean that the difference between observer and secondary counts was smaller than the difference between observer and primary counts. 2) Were the secondary counts consistent with the primary counts. Here ‘consistent’ means that there was less than or equal to a 3% change in value between secondary and primary.

In the majority of cases, (Table 9) secondary viewing resulted in catch counts that were closer to the observer’s count than primary. Of the 18 hauls where the counts were improved, 16 of them also had piece counts that were inconsistent with the primary viewing. This means that 16 of the 26 hauls recounted had piece counts that were closer to the observer’s count and more than 3% different from the primary count.

Table 9. Comparing the catch count between primary and secondary viewers for 26 hauls stratified across all 6 participating vessels.

Event ID	Image Quality	Observer	Primary Viewing	Secondary Viewing	Consistent	Compared to Obs
1	M	409	467	456	Consistent	Improved
2	M	125	105	121	Inconsistent	Improved
3	M	183	149	181	Inconsistent	Improved
4	M	179	161	177	Inconsistent	Improved
5	M	985	876	965	Inconsistent	Improved
6	L	759	642	807	Inconsistent	Improved
7	M	246	197	225	Inconsistent	Improved
8	M	180	93	190	Inconsistent	Improved
9	M	58	35	58	Inconsistent	Improved
10	M	145	75	145	Inconsistent	Improved
11	H	74	46	70	Inconsistent	Improved
12	H	35	26	33	Inconsistent	Improved
13	H	61	47	61	Inconsistent	Improved
14	M	804	815	815	Consistent	Equal
15	M	1196	1181	1229	Inconsistent	Unimproved
16	M	793	798	816	Consistent	Unimproved
17	M	1022	1069	1069	Consistent	Equal
18	M	606	681	671	Consistent	Improved
19	H	517	538	546	Consistent	Unimproved
20	H	278	316	317	Consistent	Unimproved
21	M	290	436	450	Inconsistent	Unimproved
22	M	947	904	962	Inconsistent	Improved
23	M	946	875	973	Inconsistent	Improved
24	H	366	357	371	Inconsistent	Improved
25	M	815	823	827	Consistent	Unimproved
26	M	1263	1173	1345	Inconsistent	Improved

This points out an important aspect of both this project and any planned implementation of EM monitoring for fisheries management; proper training and ongoing QA/QC is an essential component of these programs. The catch comparisons by total count and species composition for the EM data used in this report were well aligned with observer results. However, these results were gathered by staff that had been recently trained to build local capacity and were only able to receive an amount of training appropriate to a pilot project. Continued work experience and additional time spent on training would improve these results.

4. DEVELOPMENT OF A FISHING LOG AUDIT METHODOLOGY

EM data can be used as a stand alone at-sea monitoring system when catch is estimated by reviewing all fishing events. In this census-style program the resulting effort and catch data derived from EM would be directly used for quota management. An alternative use of EM data is with an audit-based monitoring program. Since EM data collection and data processing and analysis occur at different stages, the technology allows to for capture of all fishing activity at-sea without the need to engage in data interpretation for all of it. However, EM captures all of the fishing activity and it can be used to fully reconstruct a fishing trip in cases where the fishing

log is not deemed accurate. Benefits of an audit-based monitoring program include (Stanley, in press):

- Cost and logistically efficient monitoring since 100% coverage is achieved but only a portion of the data needs to be interpreted and analyzed when no data quality issues are detected
- Compels fishers to be involved in data reporting resulting in higher industry engagement and incentivizes improving the quality of the data provided.
- Provides catch estimates that are transparent, intuitive, and trusted by fishers since they are derived from self-reported records.
- Provides motivation for compliance since random selection of events acts as a ‘radar trap’.
- The random sample of EM data reviewed serves as a virtually independent and unbiased estimate of catch (Stanley et al., 2009).

Over the last six years, Archipelago Marine Research, Ltd. has been highly involved in the development and implementation of this type of audit program in the British Columbia, Canada hook-and-line and trap fishery. Based on this experience and the findings from the 2008 and 2010 Morro Bay EM pilot studies, we propose the following framework to serve as a starting point for developing an audit program for the Morro Bay fixed gear fishery in particular and the West Coast groundfish fishery in general.

The design of an audit depends largely on the objectives of the monitoring program. This audit framework is based on our perceived catch monitoring needs to:

- account for all catch by species (both retained and released) in the fishery;
- account for all fishing activity (time and location); and
- monitor compliance of full rockfish retention.

In addition to using EM data, we strongly suggest considering using dockside monitoring data to further validate the fishing log for retained catch, for example in terms of ensuring all catch recorded as retained in the fishing log are landed and confirming identification of similar species. For this reason we have included the use of dockside monitoring data in the proposed audit framework.

The audit would be composed of three different comparison categories (Figure 10). First, we recommend that all sensor data be interpreted to determine data completeness, EM system performance, and time and location for all fishing activity. Second, a certain proportion of fishing events would then be randomly selected to account for catch. The BC hook-and-line fishery, for example, selects 10% of fishing events per trip with a minimum of one event (i.e., if the total events are less than 14, one fishing event is reviewed; if the total events are between 15 and 24, two fishing events are reviewed, etc.). Finally, total pieces recorded as retained in the fishing log would be compared to piece counts from the dockside monitor data. An additional phase of verification involving prioritizing certain fishing events considered high risk or where rare events have been reported (e.g. fishing in closed areas) could also be added as the program matures.

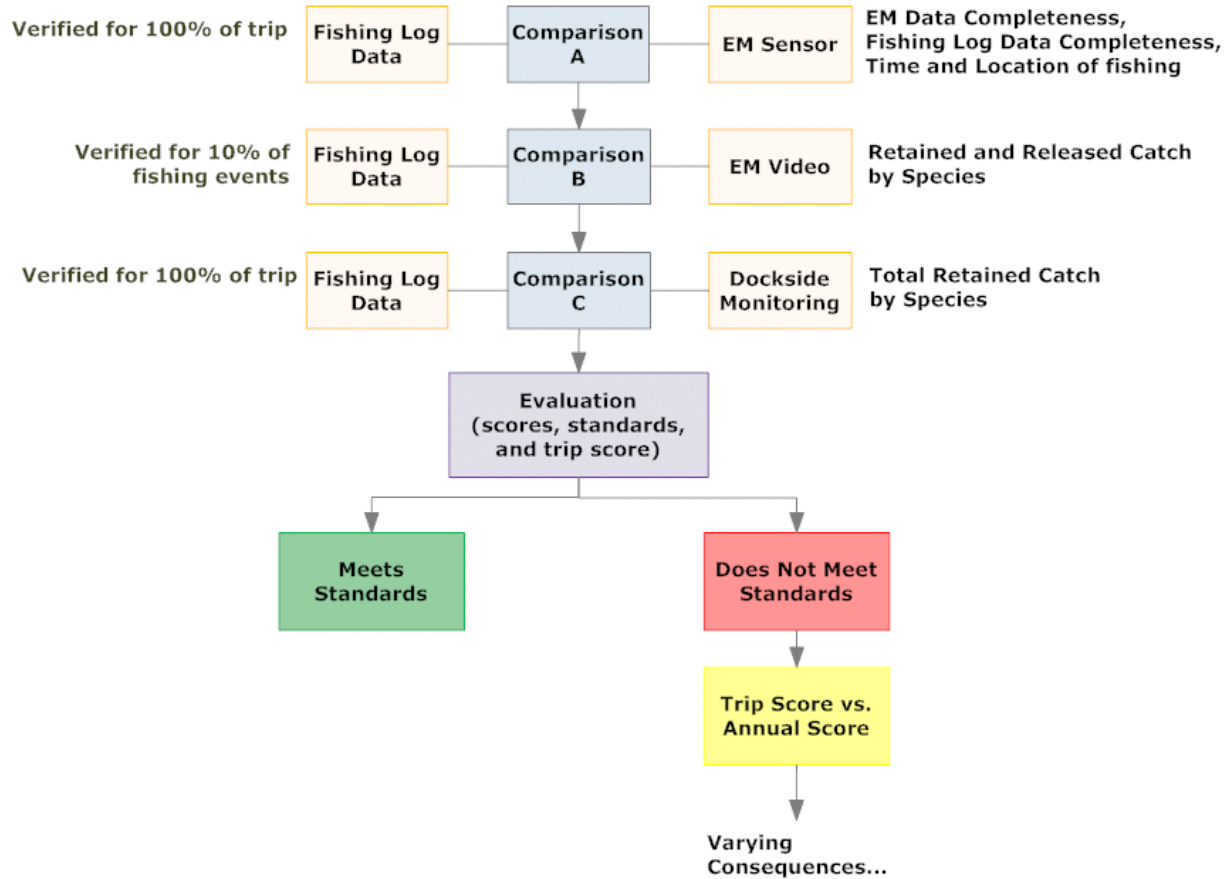

Figure 10. Conceptual audit model of the proposed comparisons to verify fishing log data.

To evaluate the data quality of logbooks against EM, the data would be put through several tests and we propose using the three different layers of evaluation methods described below. The tests shown in Table 10 are presently in use in BC and could be used as a starting point in designing the audit-based monitoring program validation for NOAA in the West Coast groundfish fishery. Further details on scores, standards and vessel history rules are described in Appendix III.

Catch evaluation is a primary focus of the monitoring program in the Morro Bay fixed gear fishery and the West Coast groundfish fishery in general and likely the most complex aspect of the audit system. This complexity is inherent in monitoring a mixed-species fishery, since there are several different species retained and/or released in a given haul and each of them has a different priority from a conservation and fisheries management perspective. The audit program must be sensitive to this level of complexity in the fishery. To start with, not all species need to be tested (even if catch information is still recorded for all), and of those tested, not all need to be tested to the same level of detail. A nested approach to testing catch would therefore be appropriate, i.e., some species may be tested separately while all catch items are pooled and tested at the haul or trip level.

Table 10. Suggested tests and evaluations to be performed in a fishing log audit using EM data.

Test	Evaluation Method	Score/Standard Example	Result
<u>Fishery management issues</u>			
Species / Species Groups by Utilization	Scoring; Standard met or not met; Score matrix.	Score based on piece counts for quota species (Table IV.1); Standard based on risk- further discussion needed	Feedback for first two years, then feedback and consequences.
Fishing time*	Standard met or not met	Within one hour	Feedback
Fishing location*	Standard met or not met	Within one nm	Feedback
Fishing management area*	Standard met or not met	Match	Feedback
<u>Data Completeness issues</u>			
EM data captured	Scoring; Standard met or not met; Score matrix.	Score based on amount of data lost and risk (e.g. transit vs. data loss at fishing grounds)	Feedback for first two years, then feedback and consequences.
All fishing events recorded in the Fishing Log	Scoring using dockside monitoring data; Standard met or not met	Score based on piece counts for quota species (Table IV.1); Match	
<u>Fishery Rules issues</u>			
Full retention of all rockfish	Standard met or not met	No rockfish species observed as discarded	Feedback for first two years, then feedback and consequences.

* Further discussion is needed to determine if both set and haul information would be required or just one or the other.

The structure of the proposed audit program is a series of steps that include collecting data, evaluating data, and providing feedback. Each stage of the program involves both fishers and managers, so that communication is ongoing. The structure of the program is outlined in a conceptual model (Figure 11). The process begins with a skipper completing a fishing trip, recording catch in the fishing logbook, and using EM equipment to collect data. Both the EM and fishing logbook data sets would then be used for processing, auditing and scoring of the trip.

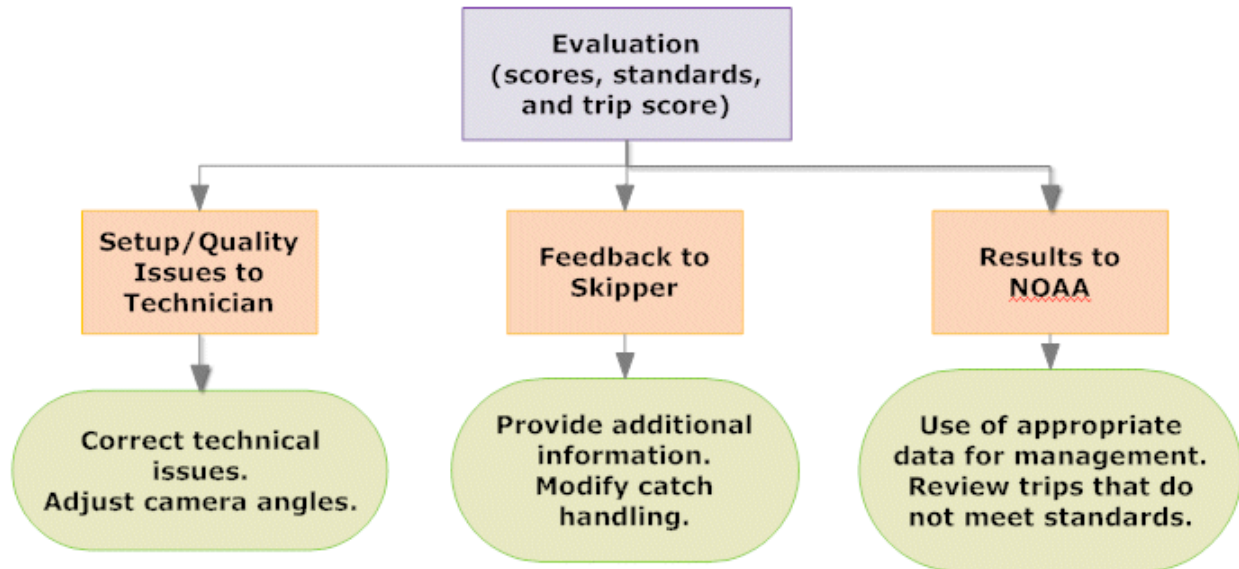

Figure 11. Conceptual model of the feedback that could be generated from the fishing log audit process to the different user groups.

Following review of the EM data, fishers and managers would be provided with a trip report summarizing the trip data and any comments on the logbook data quality. If the audit did not meet standards NOAA would make a decision on whether a full review of EM data was necessary for use in quota management. At the same time, the skipper would be given an opportunity to explain any discrepancies. If necessary, information would also be provided to the EM technician to make adjustments to the EM equipment onboard. The fisher then would take another fishing trip and the process begins again. The feedback loop allows fishers, and managers as required, the opportunity to get feedback on a continual basis and make adjustments so that data collection and quality improves.

Based on previous experiences with other similar fisheries, this feedback loop is integral to ensuring success of the program. We have seen that fisher logbooks can become a highly reliable source of data if the appropriate checks and feedback loops are put in place. The success of an EM audit-based monitoring program will be dependent on industry buy-in from an early stage, and the process and end result needs to be transparent so that all stakeholders will trust the resulting data. The collection of data for monitoring depends on fishermen completing forms, running equipment, adjusting certain catch handling behaviour, and reporting data. Findings from the 2010 Morro Bay EM Pilot Study show strong industry involvement in data collection: 100% compliance in filling out complete fishing logs, and high compliance in maintaining the EM equipment running (332 out of 338 hauls captured by EM and overall close comparisons of fishing log catch data per haul to EM).

It is advisable that an audit-based monitoring program be implemented in stages, and that during the first one or two years the emphasis is on providing feedback to industry, polishing the process and analyzing the information gathered to understand where most of the data quality issues or risks are. For the first year, scores and standards may be more like guidelines for each vessel, so that skippers are able to understand where their data records sit within the set out expectations. It would not be advisable to begin implementing consequences for poor data

quality until the program is well understood by industry and vessels operators know where they sit in relation to the standards and within overall fleet performance. The goal of an audit-based program is to obtain good quality data from industry by setting challenging but realistic goals.

5. COST STRUCTURE CONSIDERATIONS FOR EM PROGRAMS

Many factors influence cost in a monitoring program (Table 11). Some of them are determined by how the fishery operates (external factors) and others are directly related to decisions made around how the program itself operates (internal factors). It is important to note that although the same factors would need to be considered when structuring costs for any monitoring program, observer or EM, different monitoring programs may have different degrees of sensitivity to a particular factor. For example, an EM program would be less impacted by highly erratic fishing schedules than an observer program due to the ability of ensuring an operational EM system at all times and little to no cost to the program in the case of a cancelled trip vs. ensuring observer availability at all times and the costs associated with cancellations. In contrast, an observer program would be less sensitive to higher requirements for service decentralization than an EM program due to the higher infrastructure requirements needed to service equipment and retrieve data. Most of the internal factors that would influence cost on an operational EM program for the Morro Bay fixed gear fishery remain to be defined.

The cost structure of the Morro Bay EM pilot study does not provide an accurate representation of monitoring costs as the pilot study was structured very differently than a mature operational EM program would. The cost of the pilot study should be much larger than the cost of an operational EM program for three main reasons. The first reason is that the current pilot study was staged from Canada and focused on building local capacity, which resulted in expensive travel and training costs as well as necessary duplication of labour between Tenera and Archipelago staff as both groups needed to be tracking the same information related to the management of the project. These capacity building costs are expected to be the highest during pilot studies and decrease noticeably as EM programs are implemented.

Table 11. Factors that influence the cost structure of an EM and observer program.

Factors	Examples
<u>External</u>	
Fishery activity	Number of vessels, landing, fishing events and seadays
Port use patterns	Temporal and spatial distribution of the fishery
<u>Internal</u>	
Analysis and reporting requirements	Data product delivered
Overall maturity of data model	Integration of data from different sources and flow of monitoring data to quota system
Degree of program centralization	Management of the program operations centralized vs. replication necessary at various levels
Cost recovery method	Division of cost responsibilities between government and industry as well as within industry
Program responsiveness	Reporting timelines
Feedback and outreach processes	Reports, meetings, one-on-one feedback
Performance tolerances	Data quality requirements. If audit-based: additional analysis required based on initial results
Audit method and coverage level *	Amount of data that requires interpretation as well as level of detail within interpreted data

* Only a factor for audit-based programs

Equipment costs are the second reason cost structures would be significantly different between a pilot study and an operational program. This project leased equipment for the entire duration of the study whereas in an operational program equipment is often purchased and, although upfront capital costs are high, the cost of equipment is amortized across the total seadays for the lifespan of the equipment. Given that EM systems have historically lasted for up to 10 years of operation, this amortization can be significant.

The third reason for differences in cost structure was that for this study, as is true for other pilot studies, reporting requirements were complex including the writing of an interim and a formal final report with ad hoc data analysis and summaries. Once reporting requirements for an operational EM program are defined, reporting is done in a standardized way for all trips. This has the added benefit of ensuring that trips with high quality data follow a streamlined process with little or no additional time needed for further investigation to provide feedback whereas trips with fair or poor data quality follow a different path in which additional time is needed for investigation or feedback and may cause a delay in reporting along with additional expenses for the fisherman in question.

The best insight into cost structure for an EM program comes from analyzing data from existing mature EM programs for which all inputs and outputs have been defined; such as the BC hook-and-line catch monitoring program (Table 12). The BC hook-and-line monitoring program is an audit-based EM program that delivers a finished data product for a yearly average cost per vessel of 194 \$CDN (~200 \$USD) per seaday or 3.2% of the landed catch value on average (median 4.7%) (Stanley *et al.*, in press). Beyond EM monitoring, this cost also includes hail, fishing log and dockside programs as well as data editing and consolidation for all these separate programs. The monitoring program includes all data collection, interpretation and reporting to generate a finished data product, i.e. audit report and appropriate quota deductions. Some of the external and internal factors for this fishery are:

External

- 202 active vessels, 1,323 trips, 11,545 seadays and 23,192 fishing events per year
- Total landed weight of 11,789 tons with a value of 75 million Canadian dollars
- Operates out of six main ports but service is provided for a total of close to 30 ports across the BC coast.

Internal

- EM data must be retrieved after every fishing trip.
- Finished data product must be available to industry and fisheries managers within five days of landing, unless audit fails to meet standards.

Table 12. Summary of BC hook-and-line catch monitoring program costs for the 2009/2010 programme year, including funding from both industry and the Department of Fisheries and Oceans Canada and covering on average 3.2% of the landed catch value (median 4.7%) for each vessel. (Stanley *et al.*, in press).

Monitoring programme	Average cost vessel ⁻¹ year ⁻¹ (SCDN)
Hail programme	\$236
Logbooks	\$312
Dockside monitoring	\$2 890
EM equipment	\$1 760
EM field services	\$3 889
EM data services	\$2 891
EM subtotal	\$8 540
Total programme costs	\$12 053
Cost per trip	\$1 840
Cost per sea-day	\$194
Cost per kg landed	\$0.21

When all cost factors are equal, independent at-sea monitoring program options in order of lowest to highest cost are audit-based EM programs, EM census programs, and observer programs. The EM portion of the BC hook-and-line program accounts for ~70% or roughly a yearly average cost per vessel of 136 \$CDN (~140 \$USD) per seaday. Stanley *et al.* (2009) estimate that, using the same external and internal factors already defined in the BC hook-and-line catch monitoring program, if the audit-based program was substituted with an EM census program (i.e. 100% review of all video) the EM costs would increase to 274 \$CDN (~280 \$USD)

per sea day, and logistical challenges and potential additional costs would be introduced in order to meet the five day turnaround timeline. The closest estimate we have as to what an observer program would cost for this fishery comes from the offshore trawl fishery in BC which is 580 \$CDN (~597 \$USD) per seaday (although the BC offshore trawl fishery operates with 50 vessels and 4,500 seadays per year). Although these numbers are estimates, they offer valuable insight on the differences that could be expected from considering these different methods.

6 . DISCUSSION

The findings involving fishing activity time and location interpretation, catch comparisons, image quality, and catch handling, are consistent with previous work done for the 2008 EFP. Our recommendations are geared towards implementing an audit-based monitoring program using EM in the Morro Bay fixed gear fishery in particular and the West Coast groundfish fishery in general.

6.1 TECHNICAL ASSESSMENT OF EM SYSTEM

The 2010 study successfully expanded the data collected in the 2008 study by deploying equipment on six vessels for a collective total of 97 fishing trips, over 124 days at sea of EM data, and a total of 332 fishing events detected by EM. Data collected in the 2010 study represents double of that collected in 2008 by number of vessels and fishing events. Overall sensor data capture success was about 91%, however, if the equipment had not been manually turned off at the beginning and end of some trips, the capture success could have been increased and that data lost is of low risk. Six hauls were not captured by EM due to power interruption to the system and five of those corresponded to the same trip in which the EM system was only powered for 1.4 hours at the fishing grounds.

System performance and data collection success from the 2008 and 2010 studies show that it is possible to achieve virtually complete data from fishing activity using EM (97% of hauls were complete and usable for comparisons in both studies and in 2010 EM was compared to 97% of hauls detected by observers or fishing logs). More rigorous checking of the system performance before a trip starts and during the trip can further decrease the likelihood of data loss. These checks can be achieved through adequate rules within an operational monitoring program.

A further expansion in the data collection for the 2010 study was the addition of two pot/trap gear vessels in addition of longline gear vessels. Although detecting hauls from EM data was straightforward for longline gear, pot/trap vessels proved to be more challenging for detecting gear setting and matching it to hauls. One of the vessels also proved to be much more challenging for catch assessment than the other pot/trap vessel and all of the longline ones. This was caused mostly by the way catch was handled (more than one person sorting catch out of the hopper simultaneously) and periods of time when the camera view of the hopper being partially blocked by a rope. This particular challenge illustrates that not only gear differences need to be taken into account when setting up EM equipment on a vessel, but that vessel specific deck layouts and the associated catch handling are key considerations.

EM interpretation of hauls was straightforward for both longline and pot/trap gear. Overall there were few issues detected around imagery quality and catch handling. The number of medium and low quality imagery was largely due to crew and observer behaviour and inadequate lighting during night hauls in one of the longline vessels, a problem that is easily addressed in operational EM monitoring systems by providing feedback to the fishermen and making proper lighting a requirement. In fact, EM was able to successfully determine individual hauls for pot/trap gear which was problematic for the skippers and observers at first. Based on EM data early in the study it was possible to adjust the methodology for recording pot/trap fishing events in the fishing log and correct some of the observer data records. Although hauls were easy to detect, sets were only consistently detected for longline gear but inconsistent for pot/traps. Difficulties for detecting pot trap setting were primarily due to gear being set in different trips from when it was hauled as well as the short duration of those sets (five minutes for Vessel F).

Recommendation #1: We recommend developing an audit-based monitoring program structure with clear expectations for complete EM data collection (i.e. EM systems continually powered while the vessel is at sea). The program may require system checks before every fishing trip and for skippers to report any issues to the service provider. Rules around procedures in the case of system problems while the vessel is at-sea will need to be discussed.

Recommendation #2: We recommend that a document be created for each vessel that details the EM system setup (including camera views), accepted catch handling procedures to ensure they are aligned with EM cameras, deck lighting, etc. This ‘Vessel Monitoring Plan’ would be based on the initial install interview with the skipper and would serve as the basis for any feedback from data processors. The document would be a valuable reference to the EM service provider and the fishermen.

Recommendation #3: We recommend that the feedback mechanism between EM service providers and fishermen be based on the ‘Vessel Monitoring Plan’ and include information on amount of data collected per trip, catch handling procedures, and other items related to EM data quality that may affect interpretation.

Recommendation #4: If EM detection of setting activity was deemed a necessary component of at-sea monitoring program, we recommend experimenting with the use of radio frequency identification (RFID) tags to mark each line of gear. This would allow video triggering during setting to confirm sensor data time and location of setting activity for pot trap vessels and would enable connecting set and hauls together, even across different trips.

6.2 EFFICACY OF EM FOR CATCH ACCOUNTING

The basic study design to measure the accuracy of EM data used observer data as a benchmark. The assumption in this design was that observer data are currently the accepted standard in at-sea monitoring so the evaluation consisted of determining how well EM results would match observer data. However, a key problem with the method is that observer data also contain errors (Karp and McElderry, 1999). Observer error was not measured in this study but should be kept

in mind in interpreting the results of this study. The lack of agreement between observer and EM catch results can be partly attributed to unknown amounts of observer error.

Both observers and EM recorded over 105,000 pieces of catch. Fish catch was lower in observer data than in EM data with a 2% overall piece difference. These results were consistent with other studies in longline fisheries in British Columbia (McElderry *et al.*, 2003), Antarctic (McElderry *et al.*, 2005), New England (McElderry *et al.*, 2007), New Zealand (McElderry *et al.*, 2008), Florida (Pria *et al.*, 2008) and Hawaii (McElderry *et al.*, 2010).

The two most important species groups were rockfishes, including thornyheads, and sablefish, for their conservation and market values respectively. EM was very successful at detecting both and identifying catch to species groups when compared to observer data. Rockfishes had an overall difference of -4% and sablefish 1% (observer-EM). In terms of rockfish identification, EM was not able to speciate thornyheads due to the similarities between the two species and classified them as a group. Non-retention of rockfish in this study was small, with 92% of the thornyhead catch retained according to observer data. EM data for this study only had 1% identified as drop offs as well, showing that this is not a very common occurrence.

Recommendation #5: We recommend establishing a full rockfish retention rule as it was done in this study's EFP as it creates a situation where rockfish species identification can be done at the time of landing by a dockside observer since they have the advantage of handling the specimens to ensure proper identification. Rockfish discarding during transit back to port can be detected by comparing the total number of retained rockfish in the fishing log versus the number of rockfish counted at the dock. The verification of fishing log data using randomly selected EM events ensures that retained rockfish are properly accounted for at the fishing event level (mainly for area fishing information). Additionally, we recommend exploring the possibility of using depths associated with each fishing event to better determine rockfish species due to their vertical segregation in the water column.

Flatfishes and non target species also had high agreement at the species group level, but EM did not account for the full species diversity as compared to observer data. Flatfishes and bycatch also accounted for most of the discrepancies in catch disposition. Although total catch per haul had high agreement between observer and EM data, overall EM had more catch recorded as retained compared to observer data likely meaning that EM was able to detect the catch as it came on board but not its disposition. This was mainly due to catch handling procedures on deck as not all points of discard were in camera view and the observer often discarded catch en mass from a basket, not allowing for proper piece counting. The best way to deal with this problem would be through the development of more standardized catch handling procedures and modifying the camera positioning to best match these catch handling practices, or compare total catch from EM to dockside counts as the difference can be accounted to discarding. In a project setting where there is no observer on board, some of these problems would be also be eliminated as catch would not have to get put aside for sampling and the observer would not be trying to discard catch away from fishing operations to minimize obstruction.

Recommendation #6: We recommend that a subset of trips without observers be considered for participating vessels. This will allow the examination of the effect that observers have on

EM catch accounting, catch handling behaviour and fishing log entries. This will be a highly important step in any transition to any fisheries management procedure using EM systems. It would be advisable to begin this with a lower-risk section of the fishery, for example vessels that are targeting deep water species and are less likely to encounter overfished rockfish species. Using these criteria, many of the trips monitored as part of this study could be selected for inclusion in this test.

Recommendation #7: Once EM is monitoring non-human observed trips, there will be a period for fishermen to establish consistent catch handling processes to facilitate catch disposition detection by EM, which would increase efficiency of the imagery review and could also improve efficiency of catch processing. Feedback from EM data processors will play a key part in achieving this as well as the documentation process for the Vessel Monitoring Plan.

6.3 EFFICACY OF EM FOR AUDITING FISHING LOG DATA

An improvement seen from the 2008 study was that in the current study all fishing events were recorded by the fishing log. Although ensuring proper alignment between EM and fishing log data using date and time information was still challenging in some cases, all fishing events captured by EM were able to be aligned with fishing log records. In an audit-based monitoring program where fishermen are paying for at least part of the processing cost, there are economic incentives for providing data that facilitates adequate alignment with EM.

Recommendation #8: Improved data collection can be achieved by providing in season feedback to the fishermen using the audit framework proposed in this report. Alignment between the two data sets can also be aided through the proposed feedback from EM data processors, using the event marker function available in the EM system to mark sets and hauls in the EM data record, and the use of electronic fishing logs that facilitate data merging.

Fishing log data had very high agreement for target species catch records with EM, with fishing log underestimating both rockfish and sablefish pieces per set by 2% of the EM average piece counts. Another improvement from the 2008 study was better alignment in catch between EM and fishing logs, especially as it related to released catch. Even though there is room for fishermen to improve their data for released catch, modifications in the fishing log design since 2008 allowed for better records of discarded catch in the fishing log and are reflected in this study's results. This was most notably in the degree to which released catch was speciated in the fishing log but also in some improvement on the pieces recorded per species.

The audit framework proposed in this report is intended to act as a starting point in discussions as many details would still need be to worked out. Discussions around implementing an audit-based monitoring system

Recommendation #9: We recommend that further work towards implementing an audit-based monitoring program includes discussions about which species will be tested. Species

with quotas and those with higher conservation risks should be considered. Other species may be incorporated into the audit evaluation as the program matures.

6.4 CONCLUSIONS

Implementing monitoring programs using EM technology with the fixed gear fishery in Morro Bay and other parts of West Coast should start with discussions between all stakeholders since the monitoring program must meet the needs of fisheries managers, while buy-in from industry is essential to the success of the program. An audit-based program to validate fishing log data using EM and dockside monitoring would be the most valuable approach for the reasons described above; including its potential for cost-effectiveness, providing transparent catch estimates, and engaging industry in the monitoring of their fishery. This project has led to two key conclusions for moving forward in developing an audit-based model of fishing log data:

1. Consistent with the findings of the 2008 study, EM has been demonstrated to be an effective tool for at sea monitoring, delivering fishing effort and catch data comparable to on-board observers. There is no need for continuing to concentrate future efforts on comparing EM data with observer data. Next steps should concentrate on developing a comprehensive monitoring program involving tools such as fisher logbooks, dockside monitoring, EM, and supplemental observers as necessary. Lower-risk parts of the fishery could be monitored with EM at first, such as trips where fishing activity is concentrated exclusively in deep waters.
2. Further work involving EM as an audit-tool should concentrate in continuing to define the audit. The audit framework described above should be used as a basis for discussion on how a program of this type would work in the Morro Bay fixed gear fishery and elsewhere in the West Coast. Fisheries managers would be required to establish the requirements of the program and fishermen would then be able to engage on how to achieve those requirements. Some of the questions that require an answer from fisheries managers include: which species should be tested, what is an appropriate turnaround time for audit results, what should the incentives and disincentives be to achieve the desired data quality from logbook data.

REFERENCES

Karp, W. A. and H. McElderry. 1999. Catch Monitoring by fisheries observers in the United States and Canada. Pages 261-284 in C. P. Nolan, editor. proceedings of the International Conference on Integrated Fisheries Monitoring. food and Agriculture Organization of the United Nations, Rome.

McElderry, H., 2005. Report for Electronic Monitoring in the Antarctic Longline Fishery. Archipelago Marine Research Ltd. Unpublished Report Prepared for the Australia Fisheries Management Authority, Canberra, ACT, Australia by Archipelago Marine Research Ltd., Victoria, BC, Canada 16 p.

McElderry, H. 2008. At Sea Observing Using Video-Based Electronic Monitoring. Background paper prepared by Archipelago Marine Research Ltd. for the Electronic Monitoring Workshop July 29-30, 2008, Seattle WA, held by the North Pacific Fishery Management Council, the National Marine Fisheries Service, and the North Pacific Research Board: The efficacy of video-based monitoring for the halibut fishery. Available online at the following website: http://www.fakr.noaa.gov/npfmc/misc_pub/EMproceedings.pdf.

McElderry, H., J. Schrader; and J. Illingworth. 2003. The Efficacy of Video-Based Monitoring for the Halibut Fishery. Fisheries and Oceans Canada, Research Document 2003/042. 79 p. Available at: http://www.dfo-po.gc.ca/CSAS/Csas/English/Research_Years/2003/2003_042_E.htm

McElderry, H., M. Dyas, R. Reidy, and D. Pahti, 2007. Electronic Monitoring of the Cape Cod Gillnet and Longline Fisheries – A Pilot Study. Unpublished Report Prepared for the Cape Cod Commercial Hook Fisherman’s Association (CCCHFA), Chatham, MA, USA by Archipelago Marine Research Ltd., Victoria, BC, Canada. 54 p.

McElderry, H., J. Schrader, and S. Anderson. 2008. Electronic Monitoring to Assess Protected Species Interactions in New Zealand Longline Fisheries: A Pilot Study. New Zealand Aquatic Environment and Biodiversity Report No. 24. 39p.

McElderry, H., M. J. Pria, M. Dyas, R. McVeigh. 2010. A Pilot Study Using EM In The Hawaiian Longline Fishery. Unpublished report prepared for the Western Pacific Fishery Management Council by Archipelago Marine Research Ltd., Victoria British Columbia, Canada. 35 p.

Pria M.J., H. McElderry, M. Dyas, P. Wesley. 2008. Using Electronic Monitoring to Estimate Reef Fish Catch on Bottom Longline Vessels in the Gulf of Mexico: A Pilot Study. Unpublished report prepared for the National Marine Fisheries Service by Archipelago Marine Research Ltd., Victoria British Columbia, Canada. 42 p.

Pria M.J., H. McElderry, S. Oh, A. Siddall, R. Wehrell, 2008. Use of a Video Electronic Monitoring System to Estimate Catch on Groundfish Fixed Gear Vessels in California: A Pilot Study. Unpublished report prepared for the National Marine Fisheries Service by Archipelago Marine Research Ltd., Victoria British Columbia, Canada. 46 p.

Stanley, R. D., H. McElderry, T. Mameezan, J. Koolman. The advantages of an audit over a census approach to the review of video imagery in fishery monitoring. (In press)

Stanley, R. D., N. Olsen, A. Fedoruk. 2009. The accuracy of yelloweye rockfish catch estimates from the British Columbia groundfish integration project. *Marine and Coastal Fisheries: Dynamics, Management, and Ecosystem Science*, 1: 354–362.

ACKNOWLEDGMENTS

This project was funded by The Nature Conservancy. We are grateful for the cooperation and support of the vessel owners and crew who carried EM equipment aboard their vessels and provided feedback throughout the field season. We thank Steve Rienecke for assisting in field operations and offering valuable insights into the fishery. We are very appreciative of TENERA Environmental staff for their work in coordinating field services as well as data interpretation and archiving, especially Jay Carroll, John Hedgepeth, Gery Cox, Andrew Harmer, Greg Salas and Curtis Brumit. We also appreciate the support and advice of Michael Bell throughout this study and Mary Gleason for her constructive suggestions to improve this report.

APPENDIX I – EM TECHNICAL SPECIFICATIONS

Overview of the EM System

The EM systems operate on the ship's power to record imagery and sensor data during each fishing trip. The software can be set to automatically activate image recording based on preset indicators (e.g. hydraulic or winch threshold levels, geographic location, time of day,). The EM system automatically restarts and resumes program functions following power interruption, or if a software lockup is detected. The system components are described in the following sections.

Control Box

The heart of the electronic monitoring system is a metal tamper-resistant control box (approx. 15x10x8" = 0.7 cubic feet) that houses computer circuitry and data storage devices. The control box receives inputs from several sensors and up to four CCTV cameras. The control box is generally mounted in the vessel cabin and powered from the vessel electrical system (Figure I.1). The user interface provides live images of camera views as well as other information such as sensor data and EM system operational status. The interface has been designed to enable vessel personnel to monitor system performance. If the system is not functioning properly, technicians can usually troubleshoot the problem based on information presented in the screen display.

EM systems use high capacity video hard drives for storage of video imagery and sensor data. The locked drive tray is removable for ease in replacement. Depending upon the number of cameras, data recording rates, image compression, etc., data storage can range from a few weeks to several months. For example, using the standard recording rate of 5 frames per second, data storage requirements are 60-100 megabytes per hour, depending upon the image compression method. Using a four-camera set up and 500-gigabyte hard drive, the EM system would provide continuous recording for 52-86 days.



Figure I.1 EM control box and user interface installations on two different vessels.

EM Power Requirements

An EM control box should be continuously powered (24hr/day) while the vessel is at sea. The EM system can use either AC or DC electrical power, however, DC is recommended. In the case of AC power, the control box is generally fitted with a universal power supply (UPS), to ensure continuous power supply. The recommended circuit capacity for an EM system is 400 watts if using 110-volts AC, or 20 amps with 12-volts DC. The EM system amperage requirements vary from about 6 amps (at 12-volts DC) when all cameras are active, to less than 3 amps without cameras (sensors only), and about 20 milliamps during the 'sleep cycle'. The EM system continuously monitors the DC supply voltage and can be set to initiate a sleep cycle to save power when the vessel is idle and the engine is off, and shut off completely when vessel power drops below critical levels. During the sleep cycle the EM system box will turn on for 2 minutes every 30 minutes to check status and record sensor data. The EM system will resume functions when the engine re-starts.

CCTV Cameras

Waterproof armoured dome cameras are generally used (Figure I.2), as they have been proven reliable in extreme environmental conditions on long-term deployments on fishing vessels. The camera is lightweight, compact and quickly attaches to the vessel's standing structure with a universal stainless steel mount and band straps. In general, three or four cameras are required to cover fish and net handling activity and areas around the vessel. In some cases it is necessary to install a brace or davit structure in order to position cameras in the desired locations (Figure I.3).

Color cameras with 480 TV lines of resolution and low light capability (1.0 lux @ F2.0) are generally used. A choice of lenses is available to achieve the desired field of view and image resolution. The cameras have an electronic iris that adjusts automatically to reduce the effects of glare or low light levels on image quality. The output signal is composite video (NTSC) delivered by coaxial cable to the control box and converted to a digital image (480 x 640 pixel resolution). Electrical power (12 volt DC) is carried to the camera on conductors packaged in a single sheath with the coaxial cable.



Figure I.2 CCTV camera installations on three different fishing vessels. Each camera has a mounting bracket and stainless steel mounting straps.



Figure I.3 Installation showing a swing arm camera mount.

GPS Receiver

Each EM system carries an independent GPS, integrated receiver and antenna, which is wired directly to the control box (there is no attached display interface). The GPS receiver is fixed to a mount on top of the wheelhouse away from other vessel electronics (Figure I.4).

The GPS receiver is a 12 channel parallel receiver, meaning it can track up to 12 GPS satellites at once while using 4 satellites that have the best spatial geometry to develop the highest quality positional fix. The factory stated error for this GPS is less than 15 metres (Root Mean Square). This means that if the receiver is placed on a point with precisely known coordinates, a geodetic survey monument for example, 95% of its positional fixes will fall inside a circle of 15 metres radius centered on that point.

The GPS time code delivered with the positional data is accurate to within 2 seconds of the Universal Time Code (UTC = GMT). The EM control box software uses the GPS time to chronologically stamp data records and to update and correct the real time clock on the data-logging computer.

When 12 volts DC is applied the GPS delivers a digital data stream to the control box that provides an accurate time base as well as vessel position, speed, heading and positional error. Speed is recorded in nautical miles per hour (knots) to one decimal place and heading to the nearest degree.

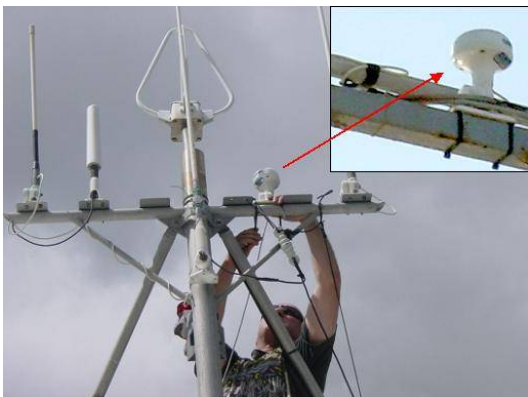

Figure I.4. GPS receiver installed in the rigging of a vessel and a close up photograph of the mounted GPS.

Hydraulic Pressure Transducer

An electronic pressure transducer is generally mounted into the vessel hydraulic system (Figure I.5 left image) to monitor the use of fishing gear (e.g., winches, line haulers, etc.). The sensor has a 0 to 2500 psi range, high enough for most small vessel systems, and a 15,000 psi burst rating. The sensor is fitted into a ¼ inch pipe thread gauge port or tee fitting on the pressure side of the hauler circuit. An increase in system pressure signals the start of fishing operations such as longline retrieval. When pressure readings exceed a threshold that is established during system tests at dockside, the control box software turns the digital video recorder on to initiate video data collection.

Drum Rotation Sensor

A photoelectric drum rotation sensor is generally mounted on either the warp winch or net drum to detect activity as vessels often deploy gear from these devices without hydraulics. The small waterproof sensor is aimed at a prismatic reflector mounted to the winch drum to record winch activity and act as a secondary video trigger. (Figure I.5 right image).



Figure I.5. A hydraulic pressure sensor installed on the supply line of a vessel line hauler (left). Drum rotation sensor (right) mounted on pelagic longline vessel, showing optical sensor and reflective surface.

APPENDIX II – EM DATA COLLECTED

Table II.1 EM data collected by Vessel, trip and haul. Departure is the date a trip started, Duration is the time from leaving port to returning in a trip, Time Gap is the amount (if any) of missing video data during a trip, Time Gap Category is the classification for the time interval that was missing (B- beginning, M- middle, E- end, N- none), Sensor Data collected should correspond to the number of hours in a trip and is also expressed as a percentage, Haul Imagery Collected reports the number of hours of video collected for that trip and the number of hauls that were recorded on video.

Vessel ID	Trip Number	Departure	Trip Duration (Hours)	Time Gap (Hours)	Time Gap Category	Sensor Data Collected (Hours)	Sensor Data Completeness (%)	Haul Imagery Collected (Hours)	Hauls Captured
A	1	12-Jul-10	20.4	0.00	N	20.4	100%	7.1	3
A	2	21-Jul-10	22.0	5.42	B	16.6	75%	7.8	3
A	3	23-Jul-10	19.9	0.00	N	19.9	100%	6.6	2
A	4	26-Jul-10	21.6	0.00	N	21.6	100%	7.1	2
A	5	28-Jul-10	23.9	0.00	N	23.9	100%	6.5	1
A	6	01-Aug-10	19.7	0.00	N	19.7	100%	7.3	2
A	7	06-Aug-10	18.9	0.03	M	18.9	100%	6.0	2
A	8	08-Aug-10	20.9	0.00	N	20.9	100%	7.2	2
A	9	24-Aug-10	42.3	0.03	M	42.3	100%	11.0	4
A	10	01-Sep-10	33.1	0.00	N	33.1	100%	7.8	3
A	11	06-Sep-10	27.1	0.00	N	27.1	100%	5.3	2
A	12	11-Sep-10	32.8	9.07	M	23.8	72%	6.2	3
A	13	24-Sep-10	25.3	0.00	N	25.3	100%	6.6	3
A	14	06-Oct-10	30.1	0.00	N	30.1	100%	7.0	3
A	15	12-Oct-10	27.3	0.00	N	27.3	100%	7.1	3
A	16	16-Oct-10	23.9	0.04	M	23.8	100%	6.4	3
A	17	20-Oct-10	5.3	0.00	N	5.3	100%	0.0	0
A	18	21-Oct-10	21.7	5.89	B	15.8	73%	7.0	2
A	19	31-Oct-10	17.9	4.36	B, M	13.6	76%	5.7	2
A	20	04-Nov-10	25.3	0.00	N	25.3	100%	8.5	2
A	21	15-Nov-10	31.6	0.00	N	31.6	100%	4.1	2
A	22	17-Nov-10	25.5	1.16	M	24.4	95%	6.9	2
A	23	26-Nov-10	27.2	0.03	M	27.2	100%	7.1	2
A	24	29-Nov-10	32.9	7.86	M	25.0	76%	7.1	2
A	25	02-Dec-10	25.8	0.03	M	25.7	100%	6.1	2
A	26	07-Dec-10	25.1	0.11	M	25.0	100%	6.2	2
A	27	15-Dec-10	18.5	0.00	N	18.5	100%	5.8	2
A	28	23-Dec-10	22.2	0.02	M	22.2	100%	4.7	2
Vessel Totals			688.1	34.0		654.1	95%	182.2	63

Vessel ID	Trip Number	Departure	Trip Duration (Hours)	Time Gap (Hours)	Time Gap Category	Sensor Data Collected (Hours)	Sensor Data Completeness (%)	Haul Imagery Collected (Hours)	Hauls Captured
B	1	21-Jul-10	20.5	7.50	B,E	13.0	63%	5.6	1
B	2	24-Jul-10	60.3	55.71	B,M,E	4.6	8%	1.0	1
B	3	28-Jul-10	23.8	0.62	M	23.2	97%	5.7	2
B	4	31-Jul-10	24.8	0.00	N	24.8	100%	7.2	2
B	5	06-Aug-10	24.7	0.00	N	24.7	100%	8.2	2
B	6	23-Aug-10	22.1	1.76	B	20.4	92%	6.3	2
B	7	25-Aug-10	21.7	0.00	N	21.7	100%	6.0	2
B	8	01-Sep-10	21.7	5.25	B,M	16.5	76%	5.7	1
B	9	03-Sep-10	22.7	0.00	N	22.7	100%	6.4	1
B	10	08-Sep-10	22.8	0.53	M	22.2	98%	6.8	1
B	11	14-Sep-10	23.1	0.05	M	23.1	100%	8.0	1
B	12	18-Sep-10	25.1	1.97	B	23.1	92%	7.7	2
B	13	20-Oct-10	23.6	0.00	N	23.6	100%	6.6	1
B	14	03-Nov-10	29.0	9.98	M	19.0	66%	7.2	1
B	15	05-Nov-10	23.2	4.18	B	19.0	82%	7.5	1
B	16	11-Nov-10	27.5	1.86	B	25.7	93%	7.6	1
B	17	15-Nov-10	25.4	0.00	N	25.4	100%	8.2	1
B	18	18-Nov-10	26.0	0.00	N	26.0	100%	9.3	1
B	19	22-Nov-10	15.6	0.00	N	15.6	100%	0.0	0
B	20	26-Nov-10	31.9	0.00	N	31.9	100%	9.3	1
B	21	01-Dec-10	30.5	0.00	N	30.5	100%	16.6	1
B	22	06-Dec-10	34.4	16.43	B,M	17.9	52%	8.0	1
B	23	14-Dec-10	29.3	2.97	B	26.3	90%	9.4	1
B	24	22-Dec-10	26.0	10.33	B	15.7	60%	7.0	1
Vessel Totals			635.8	119.1		516.7	81%	171.3	29

Vessel ID	Trip Number	Departure	Trip Duration (Hours)	Time Gap (Hours)	Time Gap Category	Sensor Data Collected (Hours)	Sensor Data Completeness (%)	Haul Imagery Collected (Hours)	Hauls Captured
C	1	07-Jul-10	32.0	0.00	N	32.0	100%	9.9	3
C	2	12-Jul-10	27.0	0.00	N	27.0	100%	9.0	2
C	3	20-Jul-10	34.2	0.05	M	34.2	100%	10.3	3
C	4	24-Jul-10	27.4	0.00	N	27.4	100%	10.1	2
C	5	10-Aug-10	34.1	0.00	N	34.1	100%	10.5	3
C	6	17-Aug-10	28.3	0.00	N	28.3	100%	10.4	2
C	7	01-Sep-10	38.5	0.00	N	38.5	100%	12.8	3
C	8	07-Sep-10	36.7	0.00	N	36.7	100%	13.1	3
C	9	12-Sep-10	35.8	0.00	N	35.8	100%	11.9	3
C	10	17-Sep-10	34.2	0.00	N	34.2	100%	11.3	4
C	11	29-Sep-10	32.8	0.00	N	32.8	100%	9.7	3
C	12	06-Oct-10	35.1	0.00	N	35.1	100%	12.7	3
C	13	13-Oct-10	32.6	0.00	N	32.6	100%	11.2	3
C	14	30-Oct-10	22.2	0.00	N	22.2	100%	7.8	2
Vessel Totals			450.7	0.0		450.7	100%	150.8	39

Vessel ID	Trip Number	Departure	Trip Duration (Hours)	Time Gap (Hours)	Time Gap Category	Sensor Data Collected (Hours)	Sensor Data Completeness (%)	Haul Imagery Collected (Hours)	Hauls Captured
D	1	14-Jul-10	24.7	0.00	N	24.7	100%	6.8	2
D	2	21-Jul-10	44.1	0.02	M	44.0	100%	11.0	3
D	3	25-Jul-10	32.4	0.05	M	32.3	100%	10.6	2
D	4	28-Jul-10	30.0	0.00	N	30.0	100%	10.2	2
D	5	08-Aug-10	27.4	0.00	N	27.4	100%	9.1	2
D	6	10-Aug-10	39.7	0.00	N	39.7	100%	11.6	2
D	7	17-Aug-10	31.6	0.00	N	31.6	100%	10.5	2
D	8	24-Aug-10	28.8	0.00	N	28.8	100%	8.9	2
D	9	02-Sep-10	34.9	0.00	N	34.9	100%	10.2	3
D	10	11-Sep-10	28.0	0.00	N	28.0	100%	10.3	3
D	11	14-Sep-10	26.1	0.00	N	26.1	100%	6.6	3
D	12	24-Sep-10	33.8	32.48	B,E	1.3	4%	0.0	0
D	13	29-Sep-10	43.0	18.16	B,E	24.8	58%	7.8	2
D	14	06-Oct-10	36.7	0.00	N	36.7	100%	10.6	2
Vessel Totals			461.2	50.7		410.4	89%	124.2	30

Vessel ID	Trip Number	Departure	Trip Duration (Hours)	Time Gap (Hours)	Time Gap Category	Sensor Data Collected (Hours)	Sensor Data Completeness (%)	Haul Imagery Collected (Hours)	Hauls Captured
E	1	26-Jul-10	15.8	0.00	N	15.8	100%	4.4	2
E	2	28-Jul-10	32.4	0.00	N	32.4	100%	0.0	0
E	3	31-Jul-10	44.4	0.00	N	44.4	100%	6.7	8
E	4	04-Aug-10	14.1	0.00	N	14.1	100%	0.0	0
E	5	09-Aug-10	61.0	0.00	N	61.0	100%	10.5	10
E	6	14-Aug-10	26.2	0.00	N	26.2	100%	5.5	6
E	7	17-Aug-10	29.3	0.00	N	29.3	100%	5.9	6
E	8	24-Aug-10	53.5	0.00	N	53.5	100%	9.5	10
E	9	12-Sep-10	72.3	7.49	B	64.8	90%	12.5	12
E	10	18-Sep-10	39.2	0.00	N	39.2	100%	6.0	7
E	11	25-Sep-10	22.0	3.46	B	18.5	84%	5.3	6
Vessel Totals			410.2	10.9		399.3	97%	43.4	67
F	1	14-Jul-10	57.0	5.38	M	51.6	91%	14.7	16
F	2	19-Jul-10	47.9	0.00	N	47.9	100%	10.2	12
F	3	31-Jul-10	53.0	9.64	M	43.4	82%	13.3	15
F	4	05-Aug-10	72.7	17.34	M	55.4	76%	21.2	25
F	5	12-Aug-10	55.2	0.00	N	55.2	100%	17.1	19
F	6	18-Aug-10	59.6	15.28	M	44.4	74%	14.4	17
Vessel Totals			345.6	47.6		297.9	86%	90.9	104
Overall Totals		97	2991.6	262.5		2729.1	91%	762.7	332

The duration of time gaps at the beginning or end of a trip were obtained from observer data.

APPENDIX III – SCIENTIFIC AND COMMON NAMES OF ENCOUNTERED SPECIES AND GROUPS

Table III.1 Scientific and common names for all fish species and groups recorded in the observer, fishing log and EM data sets.

Species Name	Scientific Name
Aurora Rockfish	<i>Sebastes aurora</i>
Black Skate	<i>Bathyraja trachura</i>
Blackgill Rockfish	<i>Sebastes melanostomus</i>
Blue Shark	<i>Prionace glauca</i>
Brown Cat Shark	<i>Apristurus brunneus</i>
California Grenadier	<i>Nezumia stelgidolepis</i>
California Slickhead	<i>Alepocephalus tenebrosus</i>
Cat Sharks	<i>Scyliorhinidae</i>
Chilipepper Rockfish	<i>Sebastes goodei</i>
Deepsea Sole	<i>Embassichthys bathybius</i>
Dover Sole	<i>Microstomus pacificus</i>
Filetail Cat Shark	<i>Parmaturus xaniurus</i>
Flatfish (unidentified)	<i>Pleuronectidae</i>
Giant Grenadier	<i>Albatrossia pectoralis</i>
Grenadier (unidentified)	<i>Macrouridae</i>
Hagfish (unidentified)	<i>Myxinidae</i>
Lamprey	<i>Petromyzontidae</i>
Longnose Cat Shark	<i>Apristurus kampae</i>
Longnose Skate	<i>Raja rhina</i>
Pacific Flatnose	<i>Antimora microlepis</i>
Pacific Grenadier	<i>Coryphaenoides acrolepis</i>
Pacific Hagfish	<i>Eptatretus stouti</i>
Pacific Hake	<i>Merluccius productus</i>
Pacific Pomfret	<i>Brama japonica</i>
Pacific Sleeper Shark	<i>Somniosus pacificus</i>
Pinkrose Rockfish	<i>Sebastes simulator</i>
Popeye Grenadier	<i>Corphaenoides cinereus</i>
Rockfish (unidentified)	<i>Sebastes/Sebastolobus</i>
Rosethorn Rockfish	<i>Sebastes helvomaculatus</i>
Sablefish	<i>Anoplopoma fimbria</i>
Sandpaper Skate	<i>Bathyraja kincaidii</i>
Sharks (unidentified)	<i>Chondrichthyes</i>
Skate (unidentified)	<i>Rajidae</i>
Spiny Dogfish Shark	<i>Squalus acanthias</i>
Spotted Ratfish	<i>Hydrolagus colliei</i>
Thornyheads	<i>Sebastolobus</i>

APPENDIX IV – DETAILS OF A PROPOSED FISHING LOG AUDIT METHODOLOGY

This appendix contains a description of three possible audit evaluation methods as well as the specific examples currently used in the British Columbia hook-and-line and trap fishery audit.

Scores: Scores are assigned to individual comparisons (e.g., retained piece differences between EM and fishing log for a specific species). Table IV.1 shows the scoring methodology for the BC hook-and-line fishery as an example. Results are calculated based on total piece differences or percentage of piece differences depending on the total number of pieces compared. Percentages are a powerful way of comparison when dealing with a large total number of pieces but become meaningless when comparing small numbers.

Table IV.1. Scoring scale used in the British Columbia hook-and-line audit-based catch monitoring program.

Score	Difference when Pieces < 30 ^{*1}	Difference when Pieces ≥ 30 ^{*1}
10	0 Pieces	0 - 2%
9	1 – 3 Pieces	2 - 10%
8	4 – 6 Pieces	10 - 20%
7	7 – 9 Pieces	20 - 30%
5	10 – 12 Pieces	30 - 40%
3	13 – 15 Pieces	40 - 50%
0	Over 15 Pieces	> 50%

^{*1} Where the number of pieces is determined by EM or Dockside Monitoring.

Standards: Standards involve binary decisions (Table IV.2), i.e., met or not met. The standard itself can be based on a particular score, an average of scores, or some other comparison result (e.g., set starts need to be within one hour).

Table IV.2. Standards used in the British Columbia hook-and-line audit-based catch monitoring program.

Comparisons	Pass Value	Interpretation
DMP to Fishing Log	9	All of the tests must be 9 or better to obtain a “pass” in the audit
Video to Fishing Log (including rockfish)	8	The average score of video to fishing log pieces must be equal to or greater than 8 to obtain a “pass” in the audit
Video to Fishing Log Rockfish Scores	7	All of the scores for the video to fishing log rockfish pieces must be equal to or greater than 7 to obtain a “pass” in the audit
Management Area fished	Match	If these areas do not match, the EM area will be used for quota deductions.
Position of set start point	Within 1 nm	Informational only. No consequence.
Date/Time of set start point	Within 1 hour	Informational only. No consequence.

Score Matrix: A score matrix is the last layer in the evaluation methodology and is used in cases when the fishing log for a trip is deemed to have low data quality and failed to meet set standards. The premise is that a skipper that has consistently underperformed should have greater consequences than someone who has consistently provided good data but failed to on a single trip. A ‘Trip Score’ is obtained by averaging all scores (each score weighted based on number of pieces per test). This trip score is then compared to the vessel’s history in the form of its average of all trip scores for the previous calendar year using a matrix such as the one shown in Figure IV.1. Depending on where a trip falls within the matrix, consequences may range from a warning to full review of all catch events in order to determine catch for the trip. Given that fishers pay for a portion of the reviewing costs, this incentivizes accurate logbook entries.

For a vessel history matrix to be meaningful and transparent it is necessary to gather a couple of years worth of data from the fleet, then plot a distribution of trip scores and decide what should the cut off for each of the categories be based on the overall performance and perceived risks.

Figure IV.1. Example of the score matrix used in the British Columbia hook-and-line audit-based catch monitoring program to rate trips based on vessel performance.

